

DV SERIES

Dry ROTARY VANE Vacuum Pumps

Models DV4, DV10, DV17, DV25, DV50

INSTALLATION
OPERATION

MANUAL

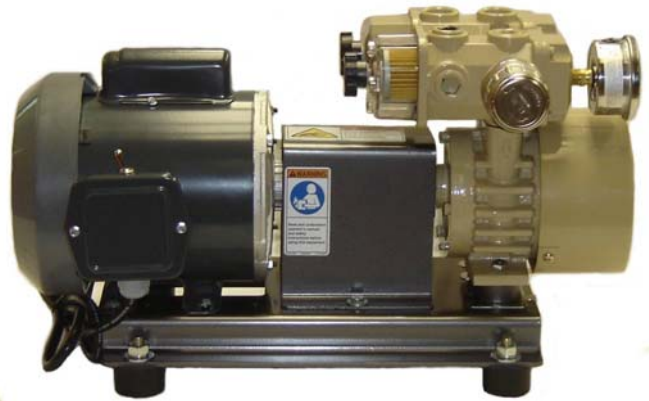

WARNING

**DO NOT OPERATE BEFORE
READING MANUAL**



US VACUUM PUMPS LLC

P.O. BOX 909
CANTON, TX USA 75103
TEL: 888-416-7366 FX: 877-416-7599
EMAIL: USVACUUM@EARTHLINK.NET
WWW.USVACUUMPUMPS.COM

FORWARD

This manual contains installation, operation, maintenance and troubleshooting information for the Model DV-4, DV-10, DV-17, DV-25 and DV-50 ROTARY VANE Dry Vacuum Pumps. Please read it in its entirety before operating the pump.

Our Vacuum Pumps are designed to ensure safety when used properly. It is the responsibility of the user to follow safety-related warnings, cautions, notes and other requirements described in this manual.

Returned equipment will not be accepted by our company without prior authorization. Prior to shipping please call for a returned goods authorization number (RGA).

Our company reserves the right to cancel the warranty if the pump is disassembled without authorization, if pump fluids are used that are not compatible with the design and materials used in the manufacturer of the pump, and if unauthorized spare parts are used.

WARNING

The pumps associated with this manual use industrial systems including heavy Current/Voltage installations. Depending on the operating conditions, particularly where dangerous conditions may be present, improper handling could lead to severe personal injury or property damage.

Those responsible for safety of the installation must therefore insure that:

- ONLY QUALIFIED PERSONNEL ARE ALLOWED TO WORK ON THE MACHINE(S).
- THESE PERSONS ALWAYS HAVE AT THEIR DISPOSAL THE SUPPLIED OPERATING INSTRUCTIONS AND OTHER PRODUCT DOCUMENTATION WHEN DOING SUCH WORK, AND THEY UNDERTAKE TO FOLLOW ANY SUCH INSTRUCTIONS CONSTANTLY.
- NONQUALIFIED PERSONNEL ARE NOT PERMITTED TO WORK ON OR NEAR THE MACHINE(S).
- ALL WORK DONE ON ANY ELECTRICAL DEVICES AND ASSOCIATED EQUIPMENT (including motors, control panels, circuit panels, etc) MUST PERFORMED BY A PROPERLY TRAINED AND CERTIFIED ELECTRICIAN.
- THE WARNINGS, CAUTIONS, AND INSTRUCTIONS DISCUSSES IN THIS MANUAL CANNOT COVER ALL POSSIBLE CONDITIONS AND SITUATIONS THAT MAY OCCUR. IT MUST BE UNDERSTOOD BY THE OPERATOR THAT COMMON SENSE AND CAUTION ARE FACTORS THAT CANNOT BE BUILT INTO THIS PRODUCT, BUT MUST BE SUPPLIED BY THE OPERATOR.

SAFETY PRECAUTIONS

CAUTION: Never operate the pump if it has a damaged cord or plug. If the unit is not working properly, has been damaged or has fallen in water, please return to US Vacuum for examination and repair.

CAUTION: Keep cord away from heated surfaces. Never block any air openings or place on a soft surface where air openings may be blocked. The air openings are for ventilation of the motor inside the housing. Keep all air openings free of lint, dirt and foreign material.

CAUTION: Do not use this pump in oxygen service. Wear safety goggles or glasses when operating this product. Identify intake and discharge of the pump before using.

CAUTION: This pump may have a thermally protected electric motor and can automatically restart when the protector resets. Always disconnect power source before servicing. All electrical products generate heat, to avoid serious burns, never touch the unit during or immediately after operation.

CAUTION: Do not disassemble. Disassembly or attempted repairs if accomplished incorrectly can create electrical shock hazard. Refer servicing to a qualified service provider only.

CAUTION: Unit is provided with a three-pronged plug (120v). Be sure to connect pump to a grounded outlet only. Do not use this product where it can fall or be pulled into water or other liquids.

CAUTION: Do not use in or near explosive atmospheres where aerosol products are being used. Do not pump anything other than atmospheric air.

FOR INDOOR USE ONLY

PERFORMANCE SPECIFICATIONS

DRY VAC DV SERIES

| MODEL | DV 4 | DV 10 | DV 17 | DV 25 | DV 50 |
|------------------------|--------|-------|-------|-------|-------|
| Displacement, CFM | 4 | 10 | 17 | 25 | 48 |
| Max Cont. Vacuum ("Hg) | 25" Hg | | | | |
| Motor, Hp | 1/3 | 1/2 | 1 | 2 | 3 |
| Suction Connection | 3/8" | 3/4" | 3/4" | 3/4" | 1" |
| Speed (RPM) | 1740 | | | | 1200 |
| Weight, Lbs | 29 | 46 | 60 | 80 | 176 |
| Noise Level dBa | 62 | 70 | 70 | 73 | 76 |

GENERAL

DV rotary vane DRY vacuum pumps have been designed to give you safe, reliable and trouble-free service, provided some of the basic maintenance guidelines as set out in this manual are followed. A vacuum pump is a rotating piece of equipment and operators must exercise good judgment and follow proper safety procedures to avoid damage to the equipment or personal injury. Please review and follow all instructions in this manual before attempting to install, start or operate equipment.

All products offered by US VACUUM have been designed and manufactured for safe operation. However, the responsibility for safe operation rests with those who use and maintain these products. Your safety department should establish a safety program based on OSHA, federal, state and local codes. It is important that due consideration be given to hazards which arise from the presence of electrical power, hot liquids, toxic gases and rotating equipment. Proper installation and care of protective devices is essential to safe pump and system operation. These safety procedures are to be used in conjunction with the instructions contained in this manual.

DV non-lubricated rotary vane pumps are single-stage air-cooled pumps with no internal lubrication. The construction is heavy-duty and compact, resulting in a small footprint. The high-tech vane material provides extended vane life. Pumps are direct driven with motor mounted drive (DV-4), traditional coupling (DV-10, 17 & 25) or Belt drive (DV-50).

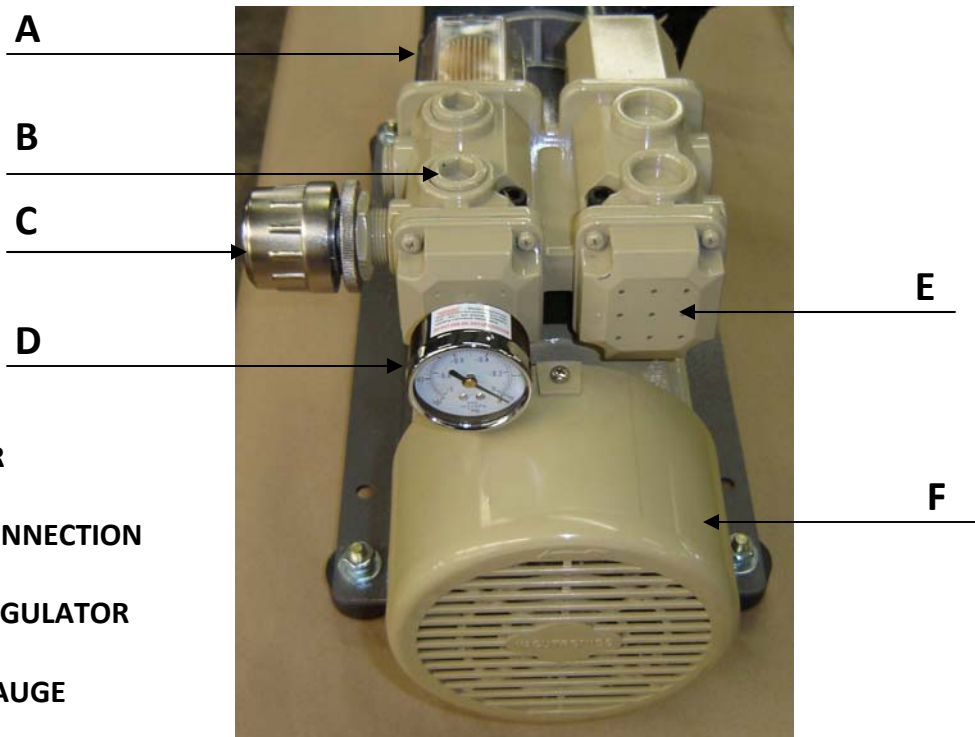

A = INLET FILTER

B = SUCTION CONNECTION

C = VACUUM REGULATOR

D = VACUUM GAUGE

E = EXHAUST

F = FAN GUARD

GENERAL (con't)

UNPACKING

Inspect the box and pump carefully for any signs of damage incurred in transit and report with-in 7 days of receipt. Since all our pumps are shipped F.O.B. our factory, such damage is the responsibility of the carrier and reported to them. The inlet & exhaust of the pumps are covered with plastic caps to prevent dirt and other foreign substances from entering the pump. Leave the caps in place until you are ready to pipe the pump to your equipment. Be sure to keep equipment in the upright position. US VACUUM products are shipped F.O.B. factory, which means that any damage is the responsibility of the carrier and should be reported to them.

LIFTING

Lift the equipment carefully and with weight evenly distributed. US VACUUM is not responsible for equipment that has been damaged through mishandling or dropping.

LOCATION

The pump comes with rubber feet attached to the pump and are excellent for mounting on semi-flexible surfaces such as a bench top; they help isolate noise and eliminate creeping...mount only on a horizontal plane.

Locate the pump in a clean, dry and well ventilated area; make sure not to block ventilation ports on the motor housing. The pump or system should be a minimum distance of 3 feet from surrounding walls to allow for checking temperatures, pressures and general servicing. The pump should be placed where the surrounding temperature remains between 10-40 Deg C (50-104 Deg F). Always check to insure location choice is protected from direct or indirect moisture contact. Install the pump at the highest point within the system to prevent possible water condensate from entering the pump.

POWER REQUIREMENTS

Various motor voltages are available depending on the model selected and application. Serious damage may occur if the motor is connected to an improper voltage supply. Single phase 120v pumps comes with a grounded power plug and must be plugged into an outlet properly grounded.

Overload Protection: If the pump motor is supplied with thermal overload protection (120v) as an aid to minimize motor failure, and is automatic, the pump may start automatic once the thermostat on the motor has reset. The pump will stop and restart automatically until the fault is detected and corrected.

VACUUM GAUGE

A 0-30"Hg vacuum gauge comes standard with all DV vacuum pump models DV-10, 17, 25 & 50. The gauge is referenced to local barometric pressure, thus variability of maximum vacuum reading will occur from day to day.

Inlet Piping

Inlet piping should be at least the size of the pump inlet. Install the unit as close as possible to the process to minimize losses due to the length of the suction line. If the unit has to be installed further away from the process, be sure that the inlet piping is oversized accordingly to minimize the overall line pressure drop.

All DV oil-free (dry) pumps are fitted with a built-in inlet filter. If the possibility exists that the inlet gas pumped contains dust or foreign particles, an additional (10 micron or finer) inlet filter should be installed at the inlet port. It is good practice to install this accessory at all times, as it will increase the life of the pump.

Discharge Piping

Do not discharge the exhaust gases from the pump or system into the area where the system is installed. Vapors pulled over from the process could be hazardous. Discharge piping should be at least the size of the pump discharge.

US VACUUM recommends the installation of a dripleg with tee on the discharge line, to prevent any condensed vapors discharged by the pump from draining back into the pump.

Before attaching the pump to a system it is well to familiarize yourself with the function and action of the vacuum pump that you purchased. Review the power requirements and safety warnings mentioned in the front of this manual.

Take every precaution to prevent foreign particulates from entering the pump. Particulates will damage the pumps' performance. Install a particulate filter in the foreline of the pump if particulates are present.

WARNING:

THE PUMP IS NOT RECOMMENDED FOR PUMPING ACID, BASE OR ORGANIC VAPORS OR GASES. PUMPING FLAMMABLE VAPORS OR GASES CAN LEAD TO SERIOUS SAFETY HAZARD LEADING TO FIRE OR EXPLOSION

LEAK DETECTION

The importance of eliminating all leaks in a vacuum system is obvious. The pump must remove this added volume of leaked gas to maintain the desired vacuum. Leaks for this pump can be located by slightly pressuring the system and painting the suspected area with a thick soap solution. Escaping air will produce soap bubbles.

OPERATING VACUUM RANGE

The pumps are designed to operate from atmosphere to their maximum vacuum level on the intake side. Max vacuum of 25"HgV

START UP

The arrow on the pump or motor indicated the proper direction the unit should rotate. Confirm rotation is correct before operating the unit online. Never let the pump rotate in the reverse direction for any period of time as this can lead to vane breakage.

- 1) Install a protective device such as overload, thermal protector or fuse in the motor electrical circuit to provide proper motor protection.
- 2) Each pump has its maximum rotational speed and should never be run in excess of this number. DV-4, 10, 17 & 25 have a maximum rpm of 1800. DV-50 maximum rpm is 1200. Check to insure maximum rpm will not be exceeded.
- 3) Turn the vacuum controller to the fully minus (-) position before energizing the electric motor. Adjust vacuum controller to desired vacuum level, not to exceed 25"HgV.
- 4) Jog the motor briefly and check direction of rotation which is marked on the pump and/or motor. A loud grinding noise and absence of vacuum is an indication of improper motor rotation. OPERATING PUMP BACKWARDS CAN CAUSE VANE FAILURE
- 5) install a foreline check valve if the pump rotates backwards when turning the pump off after initial start-up. Backwards rotation can result in vane damage.
- 6) Voltage and motor current should be checked by a qualified electrician and should be within the motor specifications. This check should be done at both start-up and under normal operating conditions.

SHUTDOWN PROCEDURES

After use, it is recommended to run the pump for about 2 minutes disconnected from the vacuum process. The air pumped through the vacuum pump will purge out water vapor or droplets of water condensate that may have formed on the inside of the pump.

MAINTENANCE

WARNING:

BEFORE ATTEMPTING ANY MAINTENANCE, DISCONNECT ALL POWER FROM THE UNIT BY SWITCHING OFF THE MAIN BREAKER OR DISCONNECT SWITCH. THIS WILL PREVENT THE UNIT FROM AUTOMATICALLY STARTING FROM A VACUUM SWITCH

SUCTION FILTER

All DV pumps come with a suction particulate filter to capture dirt, dust and other foreign material that can cause substantial damage to the pump. Check the filter after the first (8) hours of operation and every 1000-3000 hours thereafter or if excessive pressure drop is noticed.

Be careful not to allow accumulated foreign material to fall into the pump suction opening when removing the filter element. Horizontal filter installation is recommended to prevent this.

Filters must be disposed of properly as they might contain toxic substances carried over from the process.

CHANGING VANES

If the minimum height is reached (maximum wear), the whole set of vanes should be replaced. Before installing new vanes, clean the pump cylinder/rotor with compressed air. Place the new vanes inside the rotor slots with the radius outwards such that the bevel is in the direction of rotation and corresponds with the radius of the housing.

Install end plate and exhaust grid before restarting the pump.

Check for free rotation of the pump and movement of new vanes before restarting the pump. Rotate the pump by hand by turning the motor cooling fan.

Use same procedures under STARTUP for checking pump performance.

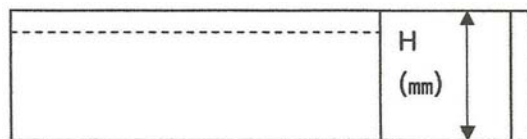

| MODEL | H= Height of New Vane (mm) | Minimum Vane Height (mm) |
|--------------|-----------------------------------|---------------------------------|
| DV-4 | 34 | 27 |
| DV-10 | 35 | 26.5 |
| DV-17 | 38 | 29.5 |
| DV-25 | 40 | 31.5 |
| DV-50 | 51 | 41 |

TROUBLESHOOTING

START-STOP PROBLEMS:

The unit will not start:

1. Check reset button on control panel. Overloads may have been triggered.
2. Check setting of HOA switch and vacuum switches.
3. Check power. Make sure that supply voltage matches motor voltage.
4. To check electrical control panel (if installed) disconnect power. Make sure that all wires are tight. Wires may vibrate loose during shipment or operation. See wiring diagram on conduit box of motor for correct wiring configurations.
5. Check motor overload in control panel (if installed). Overload settings may be too low. Set overload setting in motor starter in accordance with the motor nameplate data (include Service Factor).
6. Check fuses. Fuses may have blown.
7. Check motor wires. Motor may be wired incorrectly. Look at motor wiring diagram on conduit box of motor for correct wiring configurations. Make sure connections are secure.
8. Check wire size and length. Incorrectly sized wires can cause a voltage drop at the motor. If temperature of wire is high, use larger wire size.
9. Pump or motor may be seized. Contact factory

Unit starts, but labors and draws a very high current:

1. Stop unit and disconnect power.
2. Check motor wires. Motor may be wired incorrectly. Look at motor wiring diagram on conduit box of motor for correct wiring configurations. Make sure connections are secure.
3. Check if motor rotation is correct by comparing it to the arrow on the motor or pump housing. If incorrect switch any two of the three main power leads on the contactor inside the control panel (3-phase only).
4. Check power supply. Excessively high or low voltage or phase imbalance will damage motor.
5. Foreign particles may have carried over into pump causing damage to the vanes or other internal parts. Contact factory
6. Unit may have seized due to high temperature operation. Contact factory

VACUUM PROBLEMS

Unit is not drawing vacuum:

1. Stop unit and disconnect power.
2. Check if motor rotation is correct by comparing it to the arrow on the motor or pump housing. If incorrect switch any two of the three main power leads (3-phase power) on the contactor inside the control panel.
3. Check vacuum gauge. Gauge may be faulty. Replace.
4. Check if the inlet valve is open and inlet filter is clean.
5. Ensure that no lines are open to the atmosphere, causing loss of vacuum.
6. Check for leaks in piping systems, using conventional leak detection methods.
7. Check coupling between pump and motor (if applicable). If damaged, replace.
8. Check internal pump filter cartridge, clean or replace.
9. Check to see if inlet check valve assembly is stuck in closed position due to contamination. Disassemble and clean inlet check valve and screen as required.
10. Internal parts may be worn or damaged. Contact factory.
11. One or more of the vanes in the rotor may be stuck. Contact factory.

Unit is not reaching ultimate vacuum level:

1. Stop unit and disconnect power.
2. Check vacuum gauge. Gauge may be faulty. Replace.
3. Check to see if system is holding vacuum. This can be done by shutting the unit down and observing for about 30 minutes if the gauge on the receiver or pipe systems is holding. If vacuum is not holding, check all pipe connections for leaks using conventional leak detection methods.
4. Check internal pump filter cartridge, clean or replace.
5. Check to see if inlet check valve assembly is stuck in closed position due to contamination. Disassemble and clean inlet check valve and screen as required.
6. Internal parts may be worn or damaged. Contact factory
7. Check pump model and specifications. Pump may not be suitable for application. Consult factory

TROUBLESHOOTING (con't)

OVERHEATING PROBLEMS

Unit is overheating:

1. Stop unit and disconnect power.
2. Make sure that pump is being cooled correctly. Check that pump is located in a well-ventilated area. Maximum ambient temperature for the rotary vane vacuum pumps is 100°F. All standard pumps are air-cooled.
3. Inspect fan for damage.
4. Clean motor and pump air grills if needed.
5. Check internal inlet filter cartridge, clean or replace.

NOISE PROBLEMS:

Unit is making excessive noise:

1. Foreign particles may have carried over into the pump, causing damage to the vanes or other internal parts. Contact authorized dealer.
2. Check bearings. If bearings are noisy, contact authorized dealer for replacement instructions.
3. One or more of the vanes in the rotor may be stuck. Contact factory for instructions.

MODEL DV-4

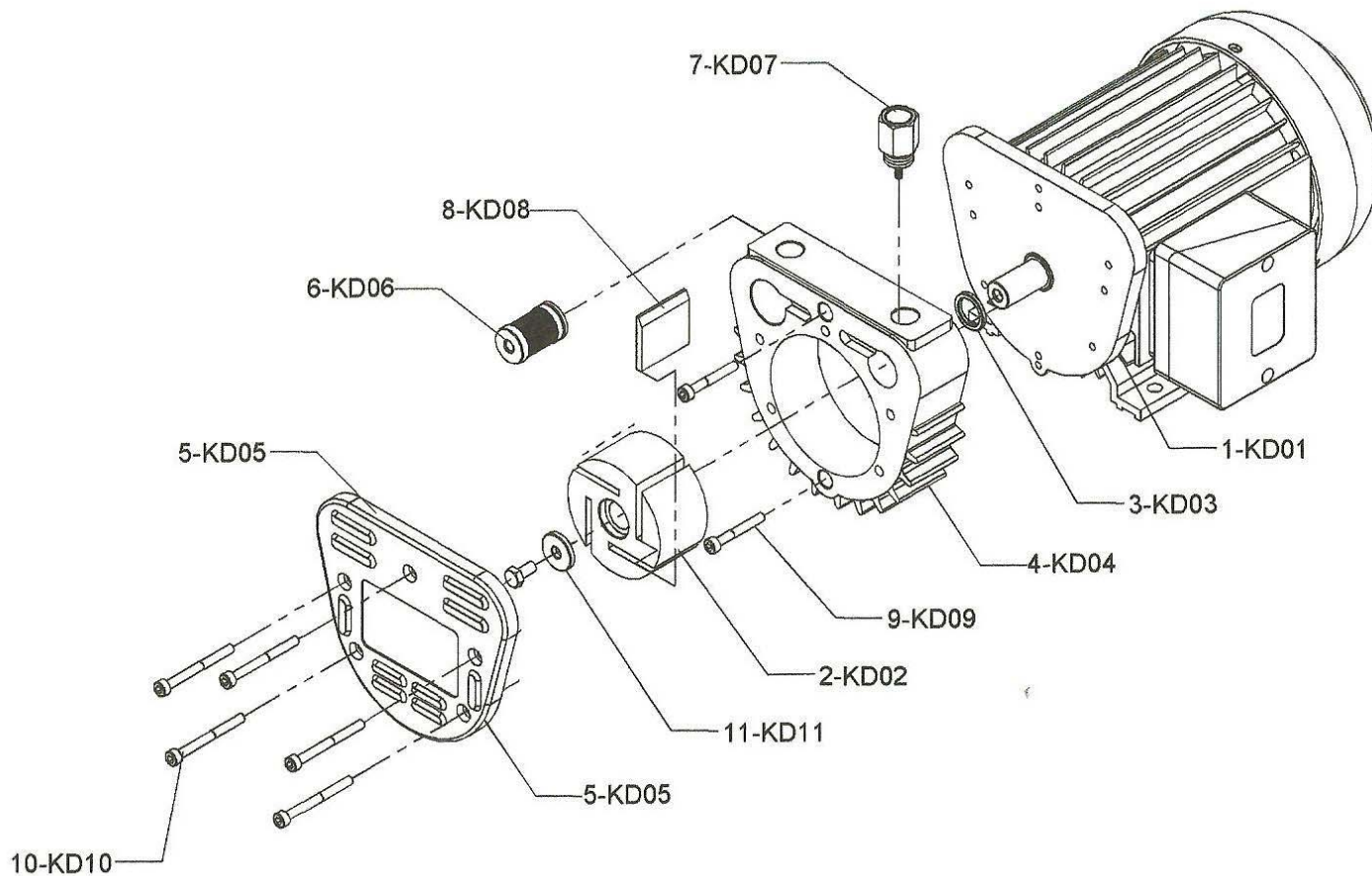

| | | |
|-----------------|---------------------------|----------|
| 1-KD01 | Back Plate | 1 |
| 2-KD02 | Rotor | 1 |
| 3-KD03 | Seal | 1 |
| 4-KD04 | Housing | 1 |
| 5-KD05 | Front cover | 1 |
| 6-KD06 | Inlet filter | 1 |
| 7-KD07 | Discharge silencer | 1 |
| 8-KD08 | Carbon vane | 4 |
| 9-KD09 | Screw 5 x 35mm | 2 |
| 10-KD10 | Screw 5 x 50mm | 5 |
| 11-KD011 | Washer | 1 |

MODEL DV-10,17,25,50

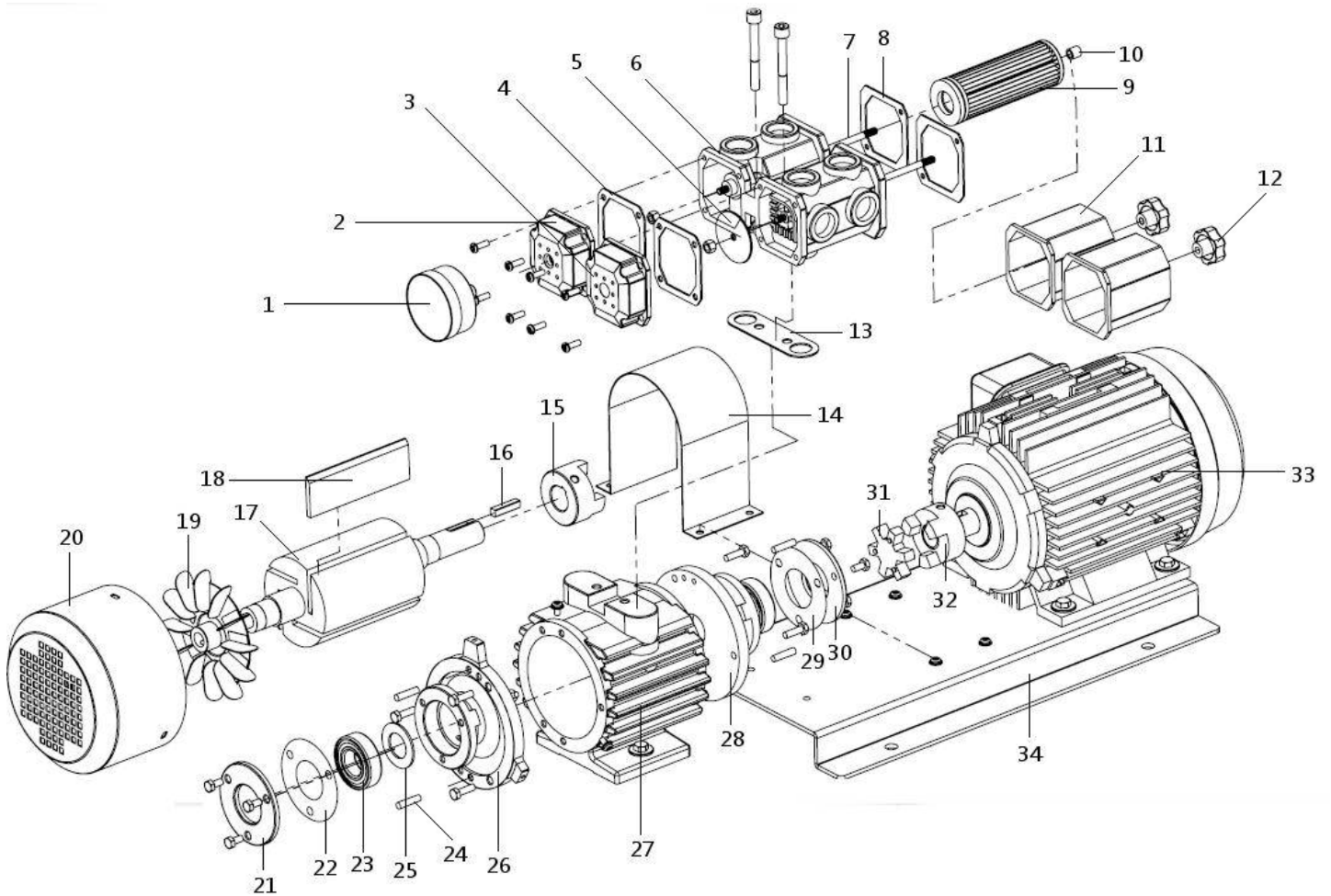

| | | | | | |
|------------------------|-----------------------|----------------------|----------------------|-----------------------|------------------------|
| 1 | 2 | 3 | 4 | 5 | 6 |
| Vacuum Gauge | Inlet Cap | Exhaust Cap | Gasket | Blade | Inlet housing |
| 7 | 8 | 9 | 10 | 11 | 12 |
| Rod | Gasket | Filter | Spring | Filter housing | Knob |
| 13 | 14 | 15 | 16 | 17 | 18 |
| Gasket | Guard | Pump coupling | Key | Rotor | Carbon vane (4) |
| 19 | 20 | 21 | 22 | 23 | 24 |
| Fan | Fan guard | Brg cover | Cover | Bearing | Pin |
| 25 | 26 | 27 | 28 | 29 | 30 |
| Retainer | End Plate,NDE | Cylinder | End Plate, DE | Cover | Brg Cover |
| 31 | 32 | 33 | 34 | | |
| Coupling insert | Motor coupling | Motor | Base | | |

WARRANTY– VACUUM PRODUCTS

Subject to terms and conditions hereinafter set forth and set forth in General Terms of Sale, US Vacuum Pumps LLC (the seller) warrants products of its manufacturer, when shipped, and its work (including installation & start-up) when performed, will be of good quality and will be free from defects in material and workmanship. This warranty applies only to sellers equipment, under use and service in accordance with seller's written instructions, recommendations and ratings for installation, operating, maintenance and service of products for a period of 12 months. Because of varying conditions of installation and operation, all guarantees of performance are subject to plus or minus 5% variation.

THIS WARRANTY EXTENDS ONLY TO BUYER AND/OR ORIGINAL END USER, AND IN NO EVENT SHALL THE SELLER BE LIABLE FOR PROPERTY DAMAGE SUSTAINED BY A PERSON DESIGNATED BY THE LAW OF ANY JURISDICTION AS A THIRD PARTY BENEFICIARY OF THIS WARRANTY OR ANY OTHER WARRANTY HELD TO SURVIVE SELLER'S DISCLAIMER.

All accessories furnished by seller but manufactured by others (motor) will bear only that manufacturer's standard warranty.

All claims for defective products, parts, or work under this warranty must be made in writing immediately upon discovery and, in any event within one (1) year from date of shipment of the applicable item by seller. Unless done with prior written consent of seller, any repairs, alterations or disassembly of sellers equipment shall void warranty. Installation and transportation costs are not included and defective items must be held for seller's inspection and returned to sellers Ex-works point upon request.

THERE ARE NO WARRANTIES, EXPRESSED, IMPLIED OR STATUTORY WHICH EXTENDS BEYOND THE DESCRIPTION ON THE FACE HEREOF, INCLUDING WITHOUT LIMITATION, THE IMPLIED WARRANTIES OF MERCHANTABILITY AND FITNESS OF PURPOSE.

After buyers submission of a claim as provided above and its approval, seller shall at its option either repair or replace its product, part, or work at the original Ex-works point of shipment, or refund an equitable portion of the purchase price.

The products and parts sold hereunder are not warranted for operation with erosive or corrosive materials or those which may lead to a build-up of material within the product supplied, nor those which are incompatible with the materials of construction. The buyer shall have no claim whatsoever and no product or part shall be deemed to be defective by reason of failure to resist erosive or corrosive action nor for problems resulting from build-up of material within the unit nor for problems due to incompatibility with the materials of construction.

Any improper use, operation beyond capacity, substitution of parts not approved by seller, or any alteration or repairs by others in such manner as in sellers judgment affects the product materially and adversely shall void this warranty.

No employee or representative of seller other than an officer of US Vacuum Pumps LLC is authorized to change this warranty in any way or grant any other warranty. Any such change by an officer of the company must be in writing.

In no event shall buyer be entitled to incidental or consequential damages. Any action for breach of this agreement must commence within (1) year after the cause of action has occurred.

NOTES