

US VACUUM

MODEL: USV-7F/15F

Oil Lubricated, Rotary Vane Vacuum Pump

INSTALLATION
OPERATION

MANUAL



WARNING

**DO NOT OPERATE BEFORE
READING MANUAL**



US VACUUM PUMPS LLC

P.O. BOX 909
CANTON, TX USA 75103
TEL: 888-416-7366 FX: 877-416-7599
EMAIL: USVACUUM@EARTHLINK.NET
WWW.USVACUUMPUMPS.COM

FORWARD

This manual contains installation, operation, maintenance and troubleshooting information for the Model USV-7F & USV-15F Rotary Vane Vacuum Pumps. Please read it in its entirety before operating the pump.

Our Rotary Vane Vacuum Pumps are designed to ensure safety when used properly. It is the responsibility of the user to follow safety-related warnings, cautions, notes and other requirements described in this manual.

Returned equipment will not be accepted by our company without prior authorization. Prior to shipping please call for a returned goods authorization number (RGA).

Our company reserves the right to cancel the warranty if the pump is disassembled without authorization, if pump fluids are used that are not compatible with the design and materials used in the manufacturer of the pump, and if unauthorized spare parts are used.

WARNING

The pumps associated with this manual use industrial systems including heavy Current/Voltage installations. Depending on the operating conditions, particularly where dangerous conditions may be present, improper handling could lead to severe personal injury or property damage.

Those responsible for safety of the installation must therefore insure that:

- ONLY QUALIFIED PERSONNEL ARE ALLOWED TO WORK ON THE MACHINE(S).
- THESE PERSONS ALWAYS HAVE AT THEIR DISPOSAL THE SUPPLIED OPERATING INSTRUCTIONS AND OTHER PRODUCT DOCUMENTATION WHEN DOING SUCH WORK, AND THEY UNDERTAKE TO FOLLOW ANY SUCH INSTRUCTIONS CONSTANTLY.
- NONQUALIFIED PERSONNEL ARE NOT PERMITTED TO WORK ON OR NEAR THE MACHINE(S).
- ALL WORK DONE ON ANY ELECTRICAL DEVICES AND ASSOCIATED EQUIPMENT (including motors, control panels, circuit panels, etc) MUST PERFORMED BY A PROPERLY TRAINED AND CERTIFIED ELECTRICIAN.
- THE WARNINGS, CAUTIONS, AND INSTRUCTIONS DISCUSSES IN THIS MANUAL CANNOT COVER ALL POSSIBLE CONDITIONS AND SITUATIONS THAT MAY OCCUR. IT MUST BE UNDERSTOOD BY THE OPERATOR THAT COMMON SENSE AND CAUTION ARE FACTORS THAT CANNOT BE BUILT INTO THIS PRODUCT, BUT MUST BE SUPPLIED BY THE OPERATOR.

SAFETY PRECAUTIONS

CAUTION: When using PVC pipe or any static enhancing material for exhaust piping, make provisions to safeguard against arcing from static electricity. Arcing can ignite oil vapor that may be present.

CAUTION: The built-in anti-suckback valve is not positive action; do not use it as a system check valve. Do not depend on the anti-suckback valve to prevent pump oil from migrating through the inlet into the system when the pump is shut down.

CAUTION: Do not use this pump in oxygen service. Oxygen service is defined as any application which has a process gas that is 25% or more oxygen.

CAUTION: After the electrical connection has been made, but before the pump is filled with oil, the rotation of the motor must be checked. Open the inlet port, jog the motor briefly to make sure rotation is correct. If it runs backwards and if wired three phase power, reverse any two leads of the three at the power connection.

CAUTION: Keep the oil fill plug tight as pressure in the exhaust box could cause bodily injury if the plug is blown out. Do not fill/add the pump with oil through the exhaust/inlet ports as there is danger of breaking vanes!

CAUTION: Do not add oil while pump is running since hot oil may escape through the oil fill port..

CAUTION: When changing the oil and filters, it may be necessary to flush the pump to remove any build-up of degraded oil from the pump. Reduced oil flow, especially through the radiator or cooling coil, can cause mechanical damage or extreme overheating, which could cause oil vapor to ignite.

GENERAL

UNPACKING

Inspect the box and pump carefully for any signs of damage incurred in transit and report with-in 7 days of receipt. Since all our pumps are shipped F.O.B. our factory, such damage is the responsibility of the carrier and reported to them. The inlet & exhaust of the pumps are covered with plastic caps to prevent dirt and other foreign substances from entering the pump. Leave the caps in place until you are ready to pipe the pump to your equipment.

LOCATION

Install the pump in a horizontal position on a level surface so that the pump is evenly supported on it's rubber feet. Leave 12-18" of access around the pump to allow proper cooling. Allow access to the oil sight glass in order to inspect the oil level, and the exhaust port for easy access to change the filters.

DO NOT TIP THE PUMP OVER IF FILLED WITH OIL

POWER REQUIREMENTS

A schematic diagram for the electric motor terminal box is located either inside the junction box cover (3 phase) or on the side of the motor itself (1 phase). The motor must be connected according to applicable electrical codes through a fused switch in order to protect the motor against electrical or mechanical overload conditions. The overload of the motor starter must be set at a level equal to the full load motor current listed on the nameplate.

AFTER ELECTRICAL CONNECTIONS HAVE BEEN MADE, BUT PRIOR TO FILLING THE PUMP WITH OIL, THE ROTATION OF THE MOTOR SHOULD BE CHECKED. IF BACKWARD, REVERSE ANY TWO LEADS OF THE THREE AT THE POWER CONNECTION.

EXTENSION CORDS

When using an extension cord with the CPS series pumps, be sure to use an extension cord with a wire gauge size of at least 10. Long cords and cords with insufficient wire size will result in voltage drop. Low voltage will cause the pump motor to stall, rotate slowly and operate at a high temperature...all leading to premature motor failure

Voltage check: While the pumps is running, check the electrical voltage AT THE PUMP motor junction box. Voltage on "110v" units should be between 115-125VAC.

VACUUM CONNECTION

Use a pipe size that is at least the size of the pump inlet connections. Smaller lines result in reduced pump capacity.

Pumps operating in parallel on a common main line should have a manual or automatic shut-off valve or positive acting check valve installed in the suction line of the pump. The pump built-in anti-suckback valve should not be Used as a shut-off valve for the vacuum system.

Should the process gas contain dust or other foreign material, a suitable inline particulate filter should be connected to the inlet port.....contact US Vacuum for recommendations.

The vacuum piping should be designed to insure that no liquids such as condensate or liquid carryover from the process can reach the pump. If this possibility exists, a knock-out liquid separator should be installed.....contact US. Vacuum for recommendations. If an exhaust manifold is used, install a drip leg near the pump exhaust port and drain to prevent exhaust condensate from entering the pump exhaust box.

MOUNTING THE PUMP/SYSTEM

Both the USV-7F/15F vacuum pump and USV-7F/15F Tank units come with rubber mounting feet for easy installation. Place the pump/tank on a level surface that can support the weight of the unit while checking that all rubber feet are securely in place and not lose from vibration in shipment. The pump/tank units are essentially vibration free, so no hold down bolts or anchors are required.

DESCRIPTION

The USV 7F/15F vacuum pump are single stage, oil sealed, rotary vane vacuum pumps. The oil separator housing is mounted directly to the cylinder exhaust. One or more internal exhaust filters separate the oil from the gas. This eliminates the need for any external oil mist eliminators. Each pump is equipped with an anti-suckback device to prevent the back streaming of oil in the event of power loss or when shutting down. The pump has an ultimate vacuum rating of 2 Torr (29.84"Hg). If the pump will be pumping particulate matter, it is advisable to install a proper inlet filter with a replaceable cartridge.

CPS-15D with secondary exhaust filter

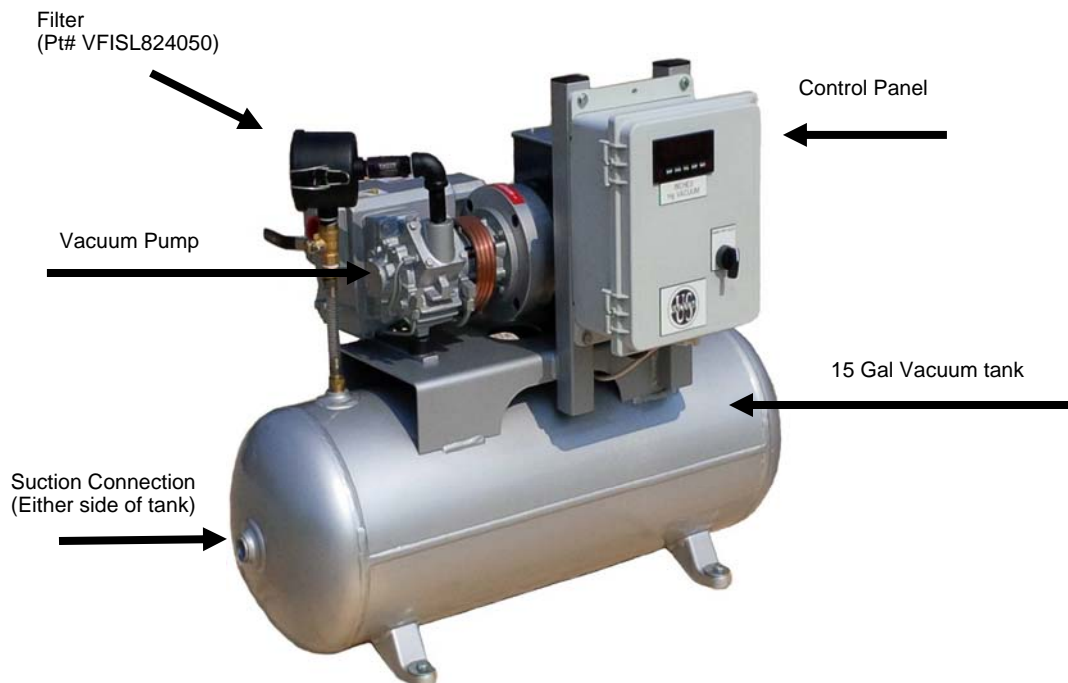
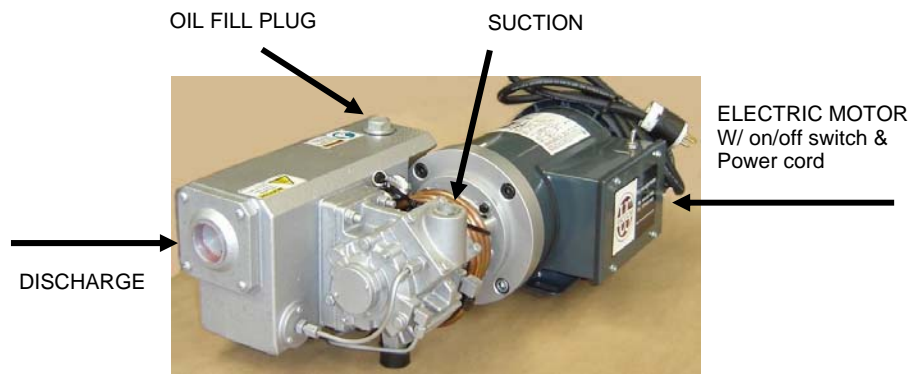

PUMP COMPONENTS

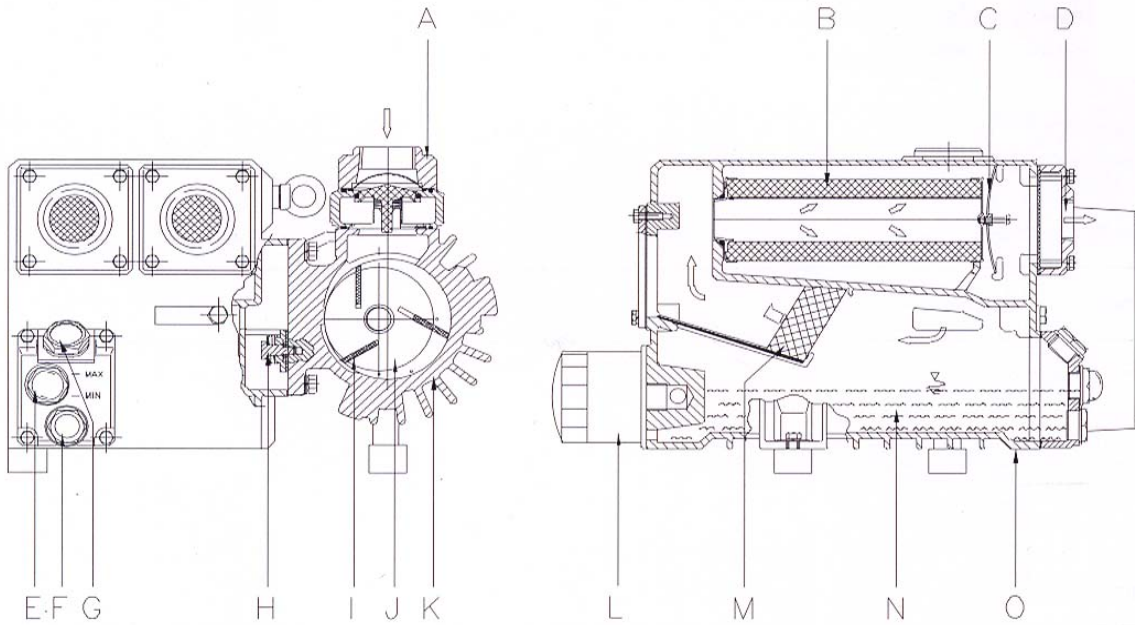

- Ⓐ Inlet flange
- Ⓑ Exhaust filter
- Ⓒ Exhaust filter spring
- Ⓓ Exhaust cover
- Ⓔ Oil sight glass
- Ⓕ Oil drain plug
- Ⓖ Oil filling plug
- Ⓗ Exhaust valve

- Ⓘ Rotor vane
- Ⓝ Rotor
- Ⓚ Cylinder
- Ⓛ Oil filter
- Ⓜ Demister
- Ⓝ Oil sump
- Ⓞ Oil separator

* Representative drawing:
All items may not be included with current model



US VACUUM PUMPS LLC

USV-7F & USV-15F

ROTARY VANE SINGLE STAGE VACUUM PUMP



General Dimensions
22" x 13" x 11"

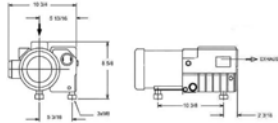
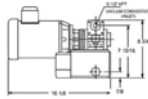

US VACUUM pumps Model USV-7F/15F are Single stage, Air-cooled, Rotary vane vacuum pump capable of producing an ultimate vacuum to 2 mm Hg (29.8" Hg).

The pumps are small and compact yet produces a very generous 7.5 & 15 cfm of inlet pumping capacity. Typical applications include vacuum drying, impregnation, food packaging, vacuum chucking and de-gassing.

Standard accessories include 110V power cord, ON/OFF switch, rubber mounting feet and inlet hose barb.

TECHNICAL DATA

PUMP TYPE		USV-7F	USV-15F
Pump Displacement	CFM	7.5	15
Ultimate Vacuum	Torr	2	2
Pump Speed	RPM	1750	3500
Oil Capacity	ml	500	500
Inlet connection	Inch	1/2"	1/2"
Motor	HP	1	1.5
Weight	LBS	45	47
Noise level	db(A)	70	72

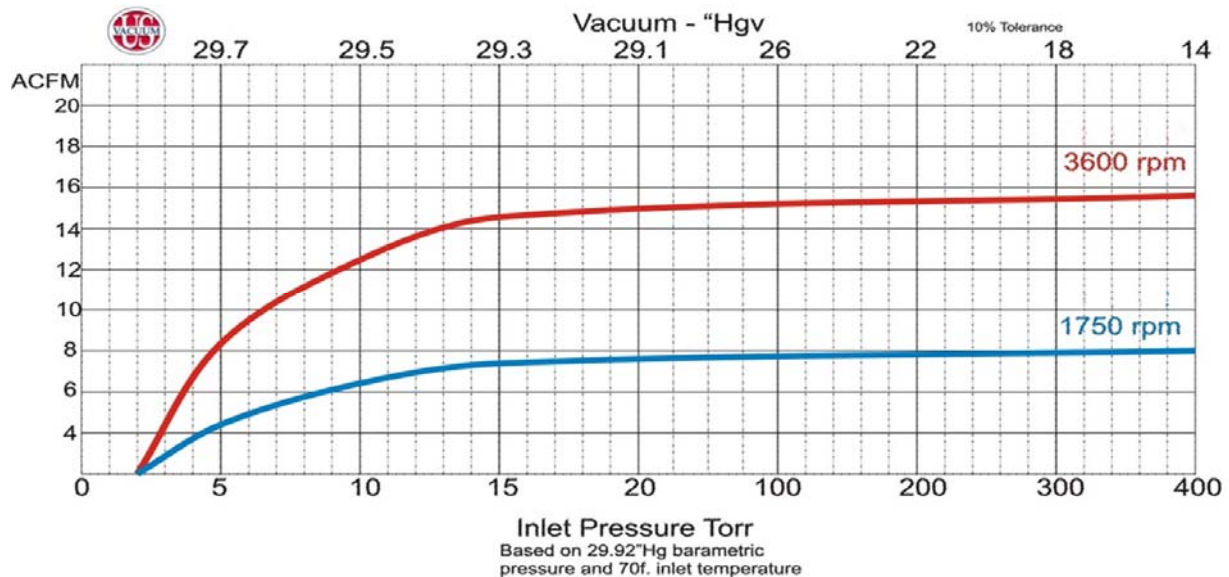

OIL FILLING

The pump is shipped without oil. After level installation and correct rotation has been established, fill the pump with recommended oil through the oil fill port. Oil level should be at the 3/4 position on the sight glass.

Non-detergent oil should be used. U.S. Vacuum recommends US-350SS oil which provides long running time between oil changes and high temperature operations. When U.S. Vacuum pump oil is used, the warranty period is extended to 18 months.

Oil capacity: 0.5 liter

CHANGE OIL EVERY 500-750 OPERATING HOURS

Check the oil for contamination on a weekly basis by shutting the pump off and draining some of the oil into a small glass or container through the oil drain port.

Oil life is dependent upon the condition to which it is exposed. The oil must be changed after the first 100 hours of initial operation. After the initial oil change, and when using US350-SS (Semi-synthetic oil), it is recommended that the oil changes are made every three (3) or four (4) months or 500-750 hours of operation, or as necessary if high heat is contaminating the oil.

To change the pump oil, the pump must be switched off and ventilated to reach atmospheric pressure. Remove the oil drain plug and drain the oil. Dispose of the oil in compliance with local or national regulations. When oil stops draining, replace the oil drain plug.

Start the pump again for a few seconds. Stop the pump once again, and then reopen the oil drain plug and discharge any remaining oil.

Refasten the oil drain plug.

EXCESSIVE HEAT:

When the pump is subjected to operating conditions that will cause the oil to be heated above 210 Deg F, the oil will carbonize and become contaminated after a relatively low number of operating hours if standard hydrocarbon oil is used. The higher the temperature, the quicker the oil becomes contaminated and thermally breaks down. In these type of high heat applications, US550SS oil is recommended.

CONTAMINATED AIR STREAM

When the air stream contains solids and/or liquids that may contaminate the oil, the oil must be changed more often. If the air stream contains a small percentage of particulate matter, the solution is to install a pre-filter or knock-out pot to keep the contaminants out of the pump.

OPTIONAL FILTERS

Optional filters are available for the USV-7F & USV-15F to meet certain needs of the of the vacuum pump in differing applications.

Inlet Filter:

Particulate inlet filter **PT# VFISL824050**. The filter is mounted on the suction of the vacuum pump to remove dirt and dust from the inlet gas stream that may contaminate and/or damage the pump.

Secondary Exhaust Filter

The USV-7F & 15F vacuum pumps come standard with an INTERNAL coalescing exhaust filter to remove oil mist and droplets from the pump exhaust. In applications where the pump will be operating in the rough vacuum range (atmospheres to 26"Hg), a secondary EXTERNAL filter may be required to capture and remove all the oil mist present in the air stream.

Secondary oil exhaust filter **PT# VFSG848125**

START-UP

Check rotation of the motor as described previously under POWER REQUIREMENTS. Fill the pump with oil as described previously under OIL FILLING. Start the pump and immediately close the inlet, Run the pump for a few minutes before checking the oil level again. With the pump shut off, the oil level should be visible in the oil sight glass between 1/2-3/4 up the sight glass.

Add oil, if necessary, but only add it when the pump has been shut off and the circulating oil has had sufficient time to return to the oil sump.

PROCESS GAS

The USV-7F/15F vacuum pump is designed to pump air and are not intended for use when water vapor is being pumped. In some applications, when the quantity of water vapor is moderate, CPS-7D/15D pumps have been used with good results. In these situations, the pump is run until it is up to operating temperature before it is allowed to pump process gas. The pump is also operated for a period of time off process and on air (to clear it of process gas) before it is shut down. This procedure prevents vapor from condensing in the pump. Before attempting to pump a gas laden with water vapor, contact U.S. Vacuum engineering for advice.

STOPPING THE PUMP

To stop the pump, turn off the power. The pump has a built-in anti-suck-back valve to prevent the pump from rotating backwards when it is shut down. Install a manual or automatic valve or check valve in each pipe leading to the pump when multiple pumps are pumping on a common header.

OXYGEN SERVICE PUMPS:

Do not use USV pumps in oxygen enriched applications that is identified as any application which has a process gas that is 25% or more oxygen.

OIL SUCKBACK LINE

The vacuum pump is equipped with an oil suckback line w/ internal float to return coalesced oil back to the pump module. The primary function of the suckback assembly is to return accumulated oil that has been coalesced by the internal oil mist exhaust filter back to the pump internals.

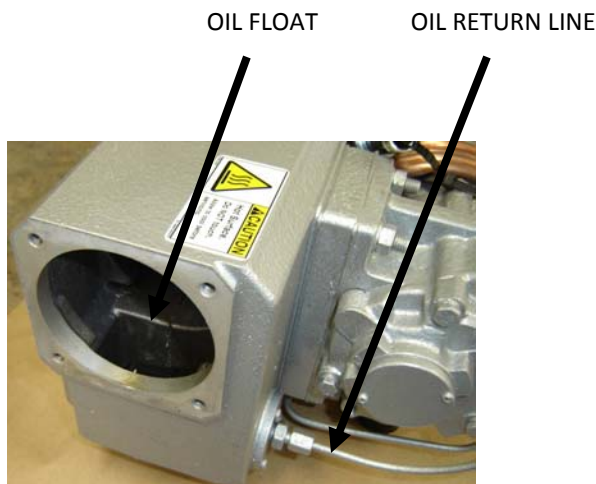

Caution

CHECK OIL LEVEL DAILY...

The oil level for the pump is measured by the oil sight glass window on the drive side of the oil box. The oil sight glass window needs to be 100% FULL for proper operation of the pump.

If the oil level drops in the sight glass window, open the air exhaust port on the pump and check for accumulation of oil in the box. Check the float for proper operation.

MAINTENANCE

Periodic Maintenance

- DAILY: Visually check oil level in sight glass & color
- Weekly: Check inlet filter
- Every 3 Months/ 500-750 hours– Change oil & spin-on oil filter
- 3000 Hours– Change exhaust filters.
- Replace coupling insert.
- 5,000-7,000 hours– Replace vanes and gaskets. This is to be done by specially trained service personnel.
- 10,000– Replace bearings and seals. This is to be done by specially trained service personnel.

US Vacuum Pumps LLC is not liable for operational failure due to mistakes during the assembling operation or the utilization of non-US Vacuum parts. Maintenance intervals may be changed according to operating conditions.

SPARE PARTS

Oil

Type US-350SS

Available in Quart, Gallon, 5-gallon pail, 55-gallon drum

Under vacuum conditions lubricating oils, especially those with additives, may behave quite differently than expected. Additives may adversely affect the attainable ultimate pressure and may react with the gas media being pumped.

For these reasons please understand that we must make our warranty commitment dependent on the use of oils which have been qualified by us. Damages caused by the use of not suitably qualified lubricating oils are not covered by our warranty.

Repair kits

Pt# USV15F-RKIT

Kit includes vanes, seals, gaskets, o-rings, exhaust filter, coupling insert

Vacuum Pump Oil

Tested to high vacuum levels, this oil meets rigid requirements for vapor pressure, stability & viscosity

Size	Cat. No
Quart	US-350SS-32
Gallon	US-350SS-128
5 Gallon	US-350SS-5
55 Gallon	US-350SS-55



Particulate Inlet Filter

Use to protect the pump from foreign Particulate matter. Replaceable element And easy change out

Pump Model	Cat. No
USV-15F	VFISL-824050
TV-40B/63B	VFISL-848125
TV-63B/100B	VFISL-848125
TV-160B/250B	VFISL-850200
TV-630B	VFISL-239300



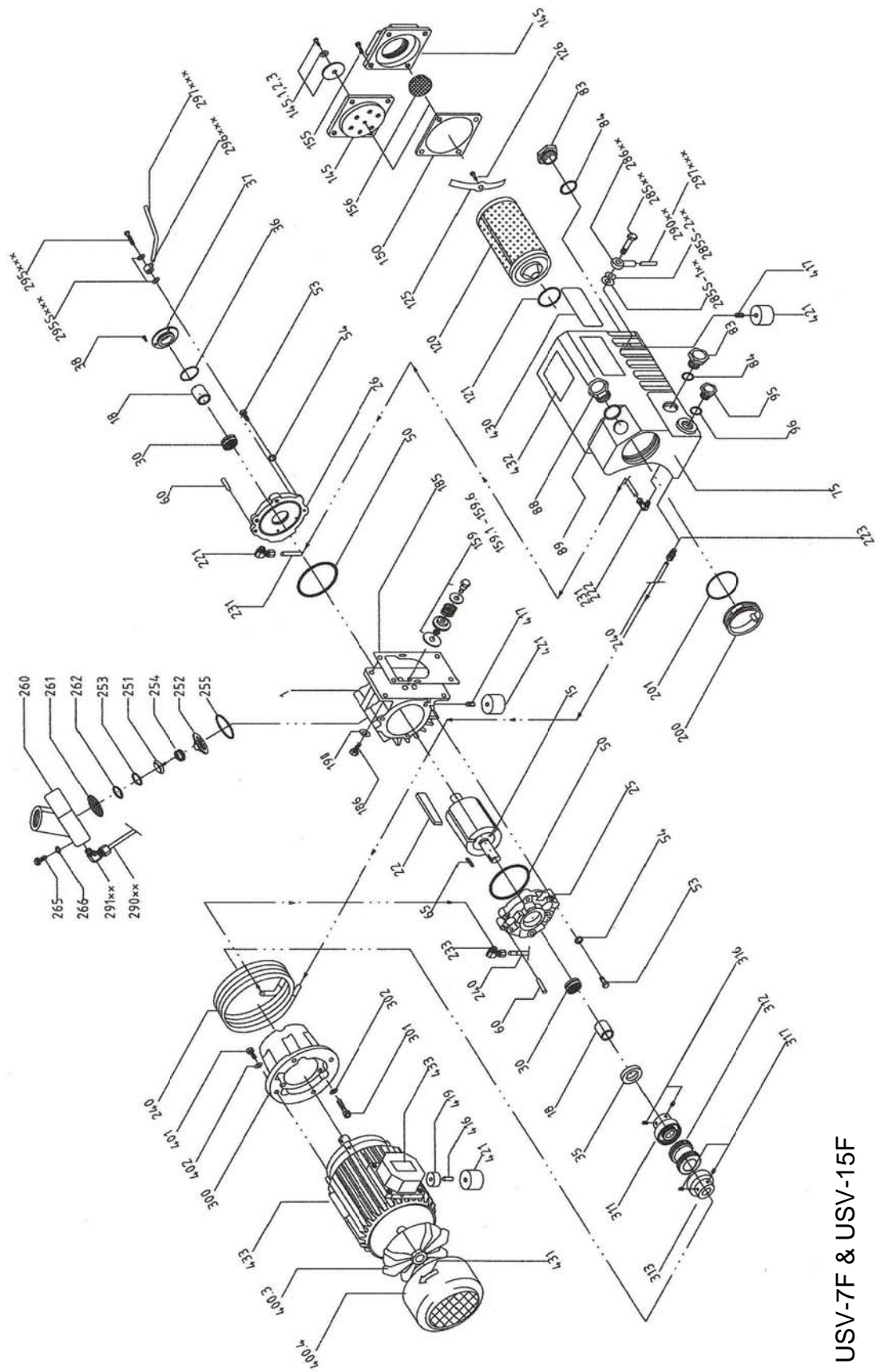

USV-7F & USV-15F

TROUBLESHOOTING

TROUBLE

The pump does not reach “blank-off” pressure or takes too long to evacuate the system.

Possible cause: Contaminated oil is the most common cause of not reaching ultimate pressure.

Remedy: Shut off the pump, after the operating temperature has been reached, drain the warm oil from the pump and change the automotive type oil filter (where applicable), if necessary. Flush and fill the pump with new oil and take a new “blank off” measurement after operating temperature is reached (20-30 minutes).

Possible cause: The vacuum system or vacuum piping is not leak tight.

Remedy: Check the hose and pipe connections for possible leak.

Possible cause: The wire mesh inlet screen is plugged.

Remedy: Clean the wire mesh inlet screen. Install an inlet filter if the problem repeats frequently.

Possible cause: No oil or not enough oil in the oil reservoir.

Remedy: Shut off the pump, add the necessary oil, or if oil seems contaminated, drain the balance of the oil from the pump, exchange oil filter and refill with fresh oil. Flush if necessary.

Possible cause: Automotive type oil filter clogged.

Remedy: Replace oil filter. Change oil if necessary.

Possible cause: The inlet anti-suck-back valve plate (ref#129) is stuck closed or partially open position due to contamination.

Remedy: Disassemble and clean if necessary.

Possible cause: Oil tubing fittings are loose and leaking.

Remedy: Replace or retighten the oil fittings or oil tubing.

Possible cause: Shaft seal is leaking.

Remedy: Replace the shaft seal.

Possible cause: Exhaust valve (ref#145) is not properly seated or it's partially stuck open.

Remedy: Contact U.S. Vacuum for instructions.

Possible cause: Vanes are stuck in rotor or otherwise damaged.

Remedy: Free vanes or replace with new ones. Contact U.S. Vacuum for instructions.

Possible cause: The radial clearance between rotor and cylinder is no longer adequate.

Remedy: Contact US Vacuum for instructions.

Possible cause: The internal parts are worn or damaged.

Remedy: Contact US Vacuum for instructions.

Possible cause: Oil tubing fittings are loose and leaking.

TROUBLE

The pump will not start

Possible cause: The motor does not have the proper supply voltage or is overloaded; the motor starter overload settings are too low or are the wrong setting; fuses burned; or the wire is too small or too long; causing a voltage drop at the pump.

Remedy: Check correct supply voltage; check overload settings in motor starter for size and setting according to motor nameplate data; check fuses; and install proper size wire. If extension Cord is used, plug pump directly into power outlet without extension cord.

Possible cause: The pump or motor is blocked.

Remedy: Remove the fan cover and try to turn the pump and motor over by hand. If frozen, remove the motor from the pump and check the motor and pump separately. If the pump is frozen, contact U.S. Vacuum for instructions.

TROUBLE

The pump starts, but labors and draws a very high current.

Possible cause: The oil is too heavy (viscosity too high) or the ambient temperature is below 41 Deg F.

Remedy: Warm up the oil before filling.

Possible cause: Pump is running in the wrong direction.

Remedy: Check for correct rotation which is counterclockwise when looking at the motor from the motor fan side. Reverse any two leads on the motor to change the direction of rotation

Possible cause: The pump is overfilled with oil or the wrong kind of oil is used.

Remedy: Correct the oil level and quality. Use recommended oil.

Possible cause: Exhaust filters in exhaust chamber are clogged and appear burned with pump oil.

Remedy: Replace exhaust filters, maintain proper oil condition, oil level and use only US Vacuum oil & filters.

Possible cause: Foreign particles in pump, vanes broken, bearings seized.

Remedy: Contact U.S. Vacuum for instructions.

TROUBLE

Pump smokes at the exhaust side or expels oil droplets from the exhaust

Possible cause: Oil suckback line needle valve closed

Remedy: Open needle valve on suckback line

to remove accumulated oil from upper housing of exhaust box

Possible cause: The exhaust filter is not properly seated with the o-ring (ref#221) in filter base or filter material is cracked.

Remedy: Exhaust filter not properly seated with o-ring, replace if necessary. Check filter spring for tightness.

Possible cause: The exhaust filter is clogged with foreign particles.

Remedy: Replace the exhaust filter.

TROUBLE

Pump runs very noisily.

Possible cause: Coupling insert worn.

Remedy: Replace coupling insert in motor/pump coupling..

Possible cause: Bearing noise.

Remedy: Contact US Vacuum for instructions.

Possible cause: Vanes stuck.

Remedy: Contact U.S. Vacuum for instructions. Use only recommended U.S. Vacuum oil and change more frequently.

TROUBLE

Pump runs hot

Note: The oil temperature with closed inlet should be approximately 185-225 Deg F depending on pump type. At 24"Hg the oil in the pump can go above 225 Deg F. These values are taken at an ambient temperature of 68 Deg F. The maximum recommended ambient operating temperature for TorrVac pumps is 100Deg F.on a Continuous basis.

Possible cause: Not enough air ventilation to the pump.

Remedy: Clean the pump and motor air grills. Clean the cooling coil. Do not install the pump in an enclosed cabinet unless sufficient amount of fresh air is supplied to the pump. Bring ambient air temperature down.

Possible cause: Automotive type oil filter is clogged and pump does not receive enough oil.

Remedy: Change oil filter.

Possible cause: Not enough oil in oil reservoir or badly burned oil used for pump lubrication.

Remedy: Drain and refill the pump only with non-detergent oil and increase oil change intervals.

TROUBLE

Pump is seized

Possible cause: The pump operated without oil and vanes broke.

Remedy: Contact U.S. Vacuum for instructions.

Possible cause: The pump operated for an extended period of time in the wrong direction.

Remedy: Inspect vanes and replace. Contact U.S. Vacuum for instructions.

Possible cause: Liquid carryover into the pump cylinder broke vanes while pump was running, or oil broke vanes on start-up.

Remedy: Install condensate trap on the inlet of the pump. Or, pump was over filled with oil in oil reservoir. Follow oil filling procedure and do not over fill.

TROUBLE

Automotive type oil filter does not get warm within two to five minutes when cold pump is started.

Possible cause: Oil filter clogged.

Remedy: Replace oil filter and change oil.

Possible cause: The wrong oil filter is used and/or oil lines leading to pump clogged.

Remedy: Use only U.S. Vacuum oil filter. Blow oil lines free, flush cooling coil.

Possible cause: Cooling coil clogged internally with burnt oil.

Remedy: Remove cooling coil and flush. Pump may have to be completely disassembled to correct severely contaminated condition.

TROUBLE

Oil disappears in oil sight glass

Possible cause: Oil is sitting in the exhaust box reservoir.

Remedy: Open oil suckback line. Oil suckback line is located underneath the exhaust port of the pump and travels to the inlet flange. Open needle valve to allow oil to flow back to the pump

END

WARRANTY– VACUUM PRODUCTS

Subject to terms and conditions hereinafter set forth and set forth in General Terms of Sale, US Vacuum Pumps LLC (the seller) warrants products of its manufacturer, when shipped, and its work (including installation & start-up) when performed, will be of good quality and will be free from defects in material and workmanship. This warranty applies only to sellers equipment, under use and service in accordance with seller's written instructions, recommendations and ratings for installation, operating, maintenance and service of products for a period of 12 months. Because of varying conditions of installation and operation, all guarantees of performance are subject to plus or minus 5% variation.

THIS WARRANTY EXTENDS ONLY TO BUYER AND/OR ORIGINAL END USER, AND IN NO EVENT SHALL THE SELLER BE LIABLE FOR PROPERTY DAMAGE SUSTAINED BY A PERSON DESIGNATED BY THE LAW OF ANY JURISDICTION AS A THIRD PARTY BENEFICIARY OF THIS WARRANTY OR ANY OTHER WARRANTY HELD TO SURVIVE SELLER'S DISCLAIMER.

All accessories furnished by seller but manufactured by others (motor) will bear only that manufacturer's standard warranty.

All claims for defective products, parts, or work under this warranty must be made in writing immediately upon discovery and, in any event within one (1) year from date of shipment of the applicable item by seller. Unless done with prior written consent of seller, any repairs, alterations or disassembly of sellers equipment shall void warranty. Installation and transportation costs are not included and defective items must be held for seller's inspection and returned to sellers Ex-works point upon request.

THERE ARE NO WARRANTIES, EXPRESSED, IMPLIED OR STATUTORY WHICH EXTENDS BEYOND THE DESCRIPTION ON THE FACE HEREOF, INCLUDING WITHOUT LIMITATION, THE IMPLIED WARRANTIES OF MERCHANTABILITY AND FITNESS OF PURPOSE.

After buyers submission of a claim as provided above and its approval, seller shall at its option either repair or replace its product, part, or work at the original Ex-works point of shipment, or refund an equitable portion of the purchase price.

The products and parts sold hereunder are not warranted for operation with erosive or corrosive materials or those which may lead to a build-up of material within the product supplied, nor those which are incompatible with the materials of construction. The buyer shall have no claim whatsoever and no product or part shall be deemed to be defective by reason of failure to resist erosive or corrosive action nor for problems resulting from build-up of material within the unit nor for problems due to incompatibility with the materials of construction.

Any improper use, operation beyond capacity, substitution of parts not approved by seller, or any alteration or repairs by others in such manner as in sellers judgment affects the product materially and adversely shall void this warranty.

No employee or representative of seller other than an officer of US Vacuum Pumps LLC is authorized to change this warranty in any way or grant any other warranty. Any such change by an officer of the company must be in writing.

In no event shall buyer be entitled to incidental or consequential damages. Any action for breach of this agreement must commence within (1) year after the cause of action has occurred.

CPS 7D/15D ACCESSORIES



0-30" Hg VACUUM GAUGE			
		CATALOG NUMBER	
USE WITH PUMP MODEL	CONNECTION SIZE	BRASS	STAINLESS
CPS-5B, CPS-8B, CPS-7D/15D	1/4"	VGBB-25	VGBS-25



INLET PARTICULATE FILTER			
		CATALOG NUMBER	
USE WITH PUMP MODEL	CONNECTION SIZE	FILTER	REPLACEMENT ELEMENT
CPS-5B, CPS-8B	3/8"	VFISL824038	824
CPS-7D/15D	1/2"	VFISL824050	824



PVC VACUUM HOSE (wire reinforced)		
USE WITH PUMP MODEL	HOSE SIZE	Catalog #
CPS-5B, CPS-8B	1/4" ID	USVH25-PVC
CPS-5B, CPS-8B	1/2" ID	USVH50-PVC
CPS-7D/15D	5/8" ID	USVH62-PVC



VACUUM PUMP OIL			
		CATALOG NUMBER	
USE WITH PUMP MODEL	TYPE	1 QUART	1 GALLON
CPS-5B, CPS-8B	HYDROCARBON	US350H-QT	US350H-GL
CPS-15B	SYNTHETIC	US350SS-QT	US350SS-GL



SECONDARY EXHAUST FILTER			
		CATALOG NUMBER	
USE WITH PUMP MODEL	TYPE	FILTER	REPLACEMENT ELEMENT
CPS-7D/15D	COALESCER	VFSG848125	SG848

NOTES