

ULTRA-VAC

TWO STAGE

Oil Lubricated, Rotary Vane Vacuum Pumps

Models US200 US400 US650 US1000 US1800

INSTALLATION
OPERATION



MANUAL

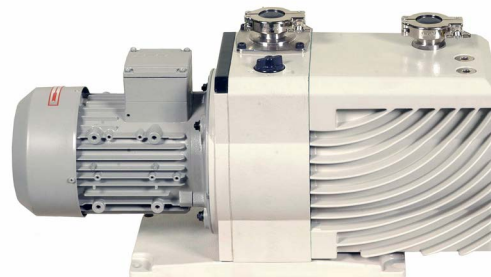

WARNING

**DO NOT OPERATE BEFORE
READING MANUAL**



US VACUUM PUMPS LLC

P.O. BOX 909
CANTON, TX USA 75103
TEL: 888-416-7366 FX: 877-416-7599
EMAIL: USVACUUM@EARTHLINK.NET
WWW.USVACUUMPUMPS.COM

Contents

FORWARD.....	2
WARNINGS.....	3
PUMP SPECIFICATIONS AND PUMP SPEED CURVES.....	4
PREPARING AND INSTALLING THE PUMP.....	7
RECEIVING.....	7
REPORTING SHIPPING SHORTAGE.....	7
REPORTING INCORRECT SHIPMENT.....	7
INITIAL FILLING WITH VACUUM PUMP FLUID.....	8
CONNECTING THE PUMP TO THE SYSTEM.....	8
STARTING AND OPERATING THE PUMP.....	9
START UP.....	9
OPERATION.....	10
ANTISUCKBACK.....	10
GAS BALLAST.....	10
MAINTAINING THE PUMP.....	11
PREVENTATIVE MAINTENANCE.....	11
TROUBLESHOOTING.....	14
DIMENSIONS.....	15

Forward

This manual contains installation, operation, maintenance, and troubleshooting information for the Model 200-7, Model 400-14, Model 650-21, Model 1000-35 and Model 1800-63 Rotary Vane Vacuum Pumps. Please read it in its entirety before operating the pump.

Our Rotary Vane Vacuum Pumps are designed to ensure safety when used properly. It is the responsibility of the user to follow safety-related warnings, cautions, notes, and other requirements described in this manual.

Returned equipment will not be accepted by our company without prior authorization. Prior to shipping please call for a returned goods authorization number (RGA).

Our company reserves the right to cancel the warranty if the pump is disassembled without authorization, if pump fluids are used that are not compatible with the design and materials used in the manufacture of the pump, and if unauthorized spare parts are used.

WARNINGS

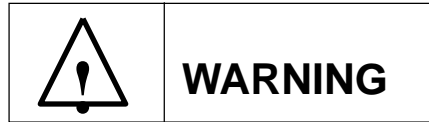

Death or serious injury can result from improper use or application of this pump. If the pump will be exposed to toxic, explosive, pyrophoric, highly corrosive, or other hazardous process gases including greater than atmospheric concentrations of oxygen, contact our company for specific recommendations.

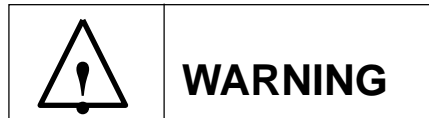

Ground the motor properly during installation. Disconnect the power before beginning installation, maintenance or repair work or before interchanging the input leads when correcting the direction of rotation. Disconnecting the power also avoids an unexpected start-up for pumps with automatically resetting thermal overloads.

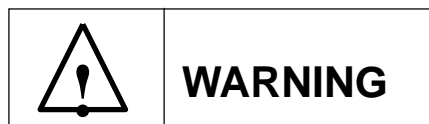

Don't run the pump without an exhaust line and an adequate exhaust system if hazardous gases or vapors are expelled from the pump. Don't exceed a maximum backpressure of 7 psig. Excessive pressure in the pump could damage the seals, blow out the sight glass, or rupture the pump housing. In addition, excessive backpressure can result in hazardous process gas or contaminated oil leaking out of the pump. Don't install an exhaust line with a smaller ID than the exhaust port or allow restrictions or deposit build up in the exhaust line. If you are purging the oil casing with inert gas, limit the inert gas flow to avoid exceeding the 7 psig limit. Accidentally connecting the pump's exhaust port to a vacuum line containing a closed valve also causes a dangerous excessive pressure.

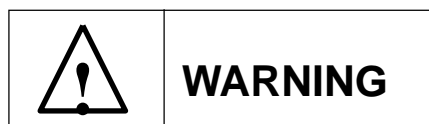

Hazardous process gases can concentrate in the vacuum pump, its oil, and its filters. If the pump has been used on toxic, explosive, pyrophoric, corrosive, volatile, or other hazardous substances, take the proper safety precautions before opening the pump or filters. Proper precautions could include inert gas purging before and after you drain the oil to sweep hazardous gas from the pump or filters; wear gloves or protective clothing to avoid skin contact with toxic or highly corrosive substances; specially ventilated work areas; fume hoods; safety masks; breathing apparatus; etc.

CAUTION

Ultra-Vac vacuum pumps are Two-Stage units designed to operate continuously in the Low torr & sub-Torr (millitorr) pressure range (<10 mmHg). Operation for prolonged periods of time above 10 mm Hg (Torr) can result in permanent damage to the pump.

Vane Pumps- Two- Stage

U.S. VACUUM

7 - 63 CFM

Vacuum to: 0.005

USV Series Rotary Vane Vacuum Pumps



USV pumps are Two-Stage Rotary Vane Air-Cooled vacuum pumps capable of producing an ultimate vacuum of .0005 mm Hg. All pumps come with an anti suck-back valve, gas ballast valve, ISO/KF connections, base & rubber feet. Single phase pumps come with 2 meter 120V power cord & on-off switch.

USV pumps are ideally suited for use in applications such as Air Conditioning & refrigeration evacuation, vacuum ovens, backing turbomolecular pumps, degassing, cylinder filling, sampling applications and others.

Models US-200/400 come standard with 1/60/115-230V
Models US-650/1000/1800 come standard with 3/60/230-460 motor.

Other motor voltages available on request.

Technical Data

MODEL		200	400	650	1000	1800
Displacement	CFM	7	14	22	35	63
Ultimate Vacuum	Torr	.0005 mm Hg				
Noise Level	dba	56	56	57	56	56
Motor	Hp	1/2	1	1	2	3
Pump Speed	RPM	1800				
Oil Capacity	Qt.	0.62	1.5	2.9	4	6.9
Inlet, ISO-KF	mm	KF25			KF40	
Pump Weight	Lbs.	53	70	114	141	194

Vacuum Pump Oil

Tested to high vacuum levels, this oil meets rigid requirements for vapor pressure, stability & viscosity

Size	Cat. No
Quart	US-350SS-32
Gallon	US-350SS-128
5 Gallon	US-350SS-5
55 Gallon	US-350SS-55



Exhaust Filter

Use when pumping continuously above 1 Torr. Captures oil mist from pump for clean oil-free discharge

Pump Model	Cat. No
US-200	EE-GL915NW25
US-400	EE-GL925NW25
US-600	VFSG848NW40
US-1000	VFSG848NW40
US-1800	VFSG850NW40



888-416-7366

DIMENSIONS (mm)

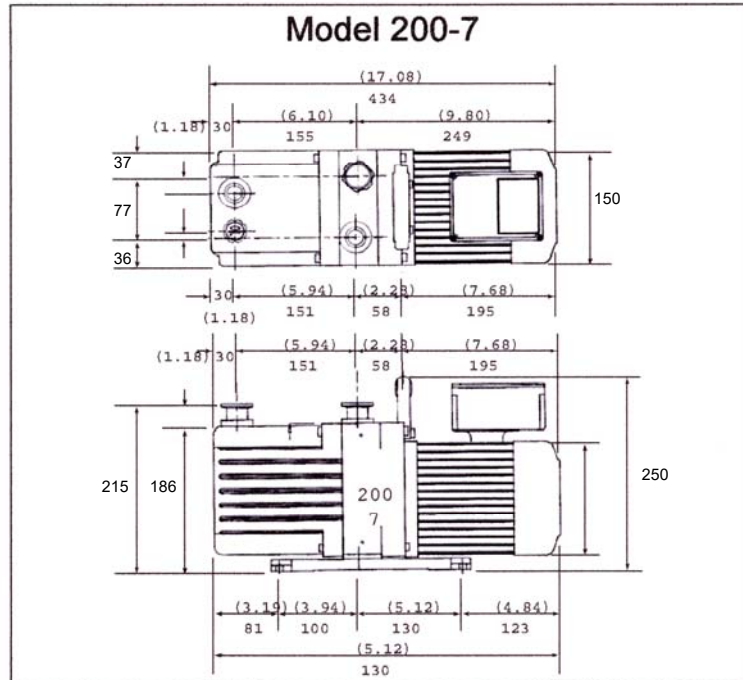

Dimensions subject to change without notice

US VACUUM PUMPS LLC

P.O. BOX 909 - CANTON, TX 75103 - (888) 416-7366 Fax (877) 416-7599

WWW.USVACUUMPUMPS.COM

DIMENSIONS (mm)

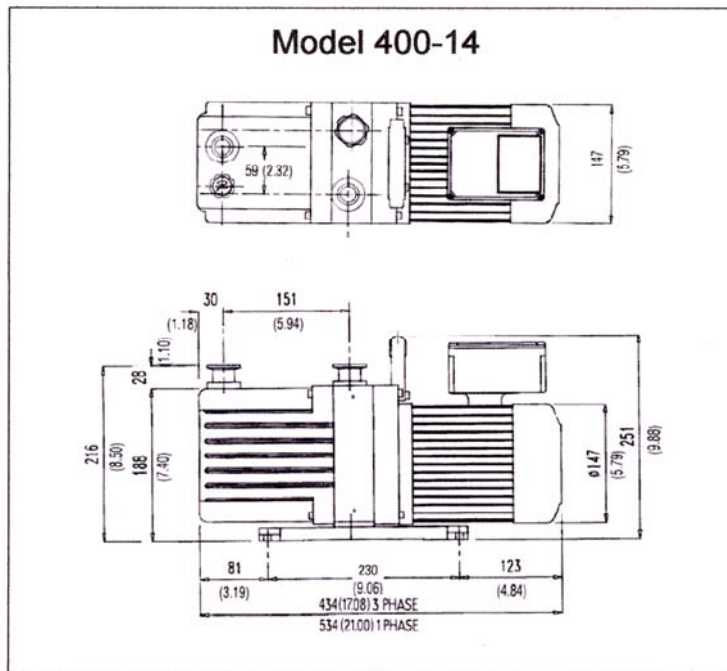

Dimensions subject to change without notice

US VACUUM PUMPS LLC

P.O. BOX 909 - CANTON, TX 75103 - (888) 416-7366 Fax (877) 416-7599

WWW.USVACUUMPUMPS.COM

DIMENSIONS (mm)

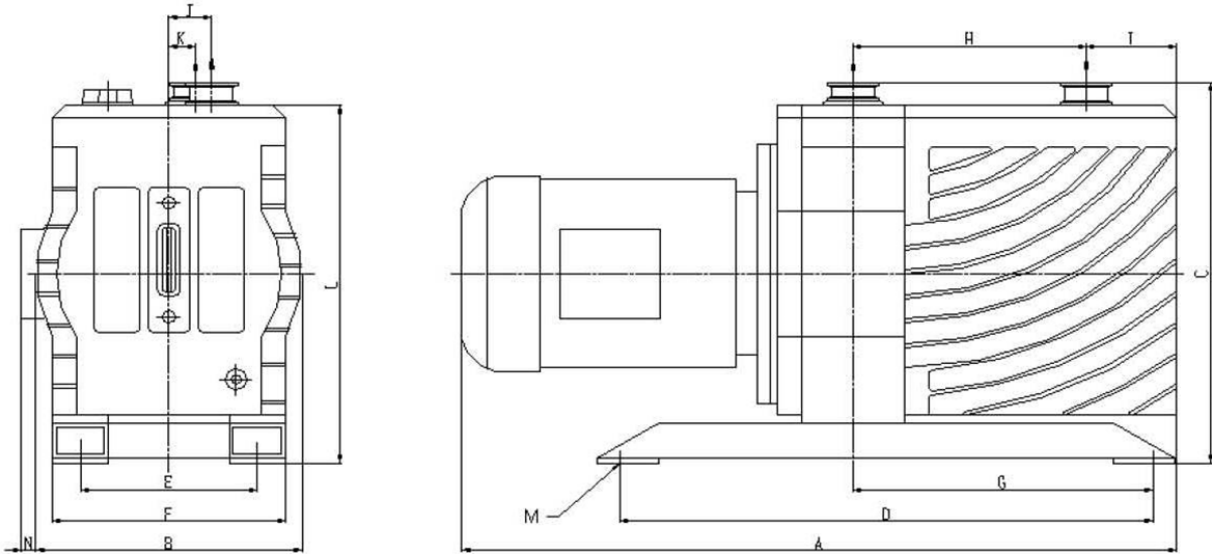

	A	B	C	D	E	F	G	H	I	J	K	L	M	N
USV650	565	205	288	310	140	180	147	186	75	40	34	262	12	48
USV1000	680	250	335	485	155	215	290	235	80	28	45	310	14	20
USV1800	801	280	410	600	185	245	360	295	95	28	45	385	14	0

US VACUUM PUMPS LLC

P.O. BOX 909 - CANTON, TX 75103 - (888) 416-7366 Fax (877) 416-7599

WWW.USVACUUMPUMPS.COM

PREPARING AND INSTALLING THE PUMP

RECEIVING

Each Rotary Vane Vacuum Pump is inspected and carefully packed prior to shipment. Inspect it after carefully unpacking it. In case of external damage, retain the shipping container and notify the shipping agency and our company immediately. Because the packing materials are designed specifically for this pump, they should always be used when transporting the pump.

Unpack the pump and check for shipping damage as follows:

1. Inspect the outside of the shipping container for shipping damage. If you will be making a damage claim, save the shipping container and packing materials.
2. Unpack the pump.
3. Carefully inspect the pump for damage.
4. If you find any damage, proceed as follows:
 - a. Save the shipping container, packing material, and parts for inspection.
 - b. Notify the carrier that made the delivery within 7 days of delivery.
 - c. File a claim with the carrier.
 - d. Contact our company to make arrangements for replacing the damaged part(s).

REPORTING SHIPPING SHORTAGE

If you did not receive all the goods that you ordered, do the following:

1. Check the number of items listed on the packing slip. If the number of pieces listed is greater than the number of shipping containers received, contact the carrier concerning the missing piece.
2. Check the packing list to see if the missing item is on back order.
3. Carefully check the packing material and container to ensure that you did not overlook the missing item.
4. If you cannot find the item, please notify our company immediately.

REPORTING INCORRECT SHIPMENT

If the item received is not the item ordered, contact our company immediately.

INITIAL FILLING WITH VACUUM PUMP FLUID

All our Rotary Vane Vacuum Pumps are shipped with a full change of vacuum pump fluid. Always be sure that the oil level is approximately in the middle of the low and high level marks in the sight glass and please note that upon start up of the pump, the oil level in the sight glass will drop slightly.

CONNECTING THE PUMP TO THE SYSTEM

KF clamps and centering rings are supplied for the intake and exhaust ports of the pump.



CAUTION! Do not connect power to your pump until the blank off plate is removed from the exhaust port. Operating the pump with the exhaust port blanked off will damage the pump and can injure the operator.

Our company also has a complete line of components, fittings, and adapters to connect your pump to any system.

All connections must be vacuum tight for your pump to achieve its ultimate pressure. The O-ring on the centering ring must be clean to avoid leaks. Be sure that all quick release clamps are in place and properly tightened.

Connect The Pump To The System As Follows:

1. Set the pump on an even horizontal surface. It need not be permanently mounted on the surface.



STARTING THE PUMP COULD RESULT IN DAMAGE TO THE PUMP.

CAUTION: FAILURE TO REMOVE THE EXHAUST PORT COVER BEFORE



WARNING: Ensure that your vacuum line is connected to the pump's intake port and not to the exhaust port. If your vacuum line has a closed valve, accidentally connecting it to the pump's exhaust port causes a dangerous overpressure.

NOTE: Ideally, the inside diameter of the vacuum line should be the same size or larger than the (ID) of the intake port. If the vacuum line is too narrow, it will reduce the pumping speed.



WARNING: Don't install an exhaust line with a smaller ID than the exhaust port. Restrictions reduce the pumping speed and could damage the oil seals or cause restrictions or closed valves in the exhaust line during operation. Such a dangerous overpressure in the pump.

2. If possible, install the exhaust line at a slightly descending angle to prevent condensate from flowing back into the pump and contaminating the pump's vacuum fluid.
3. If the exhaust line must be installed in the ascending position and the process gas contains high levels of condensable vapors, connect a condensate trap to the exhaust port. Condensate traps serve to collect the condensates from saturated vapors. Contact your distributor for more information on the correct trap for your pump.
4. If no exhaust line is connected and your pump will be running above one (1) Torr inlet pressure, connect an exhaust mist eliminator to the exhaust port to remove pump fluid vapors and smoke. Contact our company for more information on exhaust mist eliminators.
5. If the exhaust line is attached to a negative pressure exhaust system, adjust the negative pressure so that the vacuum pump fluid will not be drawn from the pump.

STARTING AND OPERATING THE PUMP

START UP

Before starting the pump, please complete the following checklist:



CAUTION! Do not connect power to your pump until the blank off plate is removed from the exhaust port. Operating the pump with the exhaust port blanked off will damage the pump and can injure the operator.

1. Be sure that the pump is filled with the appropriate amount of vacuum fluid.
2. Be sure that all electrical connections have been properly wired and that there are no bare wires that could cause an electrical shock or fire.
3. Be sure that the rotation of the pump is correct. You will find a rotational arrow on the front of the motor.
4. Be sure that all system connections have been secured with the appropriate seal rings and clamps.



WARNING: IF YOUR PUMP HAS BEEN PREPARED FOR OXYGEN SERVICE, BE SURE TO SEE IF AN EXPLOSION PROOF MOTOR IS REQUIRED.

OPERATION

1. USV Rotary Vane vacuum pumps are not designed for use in corrosive service. Standard fluid is hydrocarbon based ISO68 and designed for pumping inert gases and air.
2. Periodically check the vacuum fluid level in the sight glass to be sure it is between the low and high levels. If you are operating the pump with the gas ballast open, it will be necessary to check the oil level more frequently.
3. If the vacuum fluid within the pump becomes discolored or contaminated, change the fluid as soon as possible. Operating the pump with contaminated or dirty oil will greatly reduce the life expectancy of the pump and may lead to the cancellation of the warranty.

ANTISUCKBACK

If the pump stops with the inlet under vacuum the antisuckback system will stop air or oil leakage inside the module or into the vacuum chamber. The vacuum integrity is guaranteed by:

- Quality of machining from surfaces between the functional elements (stator, plates, housing, etc.)
- The exhaust valves on the exhaust orifice.
- A spring valve automatically closes the oil injection canal in the pump. When the pump stops, the oil pump exhaust pressure is decreased and a spring activated valve closes the oil injection canal.

GAS BALLAST

When condensable vapors (such as water vapor) are being pumped the gas is compressed beyond its saturated pressure and can condense, impairing pump performance. The vapor pressure of water at typical pump temperatures is over 100 Torr. Even small amounts of water in the pump fluid will have a big effect on pump performance. The gas ballast control button allows a quantity of air to be injected into the second stage of the pump during “compression” to reduce the partial pressure of the pumped gas below its saturated vapor pressure and thus prevent condensation.

At the end of “compression” the pressure in the discharge chamber is greater than atmospheric. The antisuckback feature described above prevents gas and oil from being discharged into the environment.

The saturated vapor pressure of pump fluid and the condensed vapors such as water is higher when it is hot than when it is cold; therefore it is necessary to wait until the pump reaches its operating temperature before pumping condensable vapor. Using the gas ballast increases the

MAINTAINING THE PUMP

PREVENTIVE MAINTENANCE

Pump Fluid

Every vacuum pump is designed to work best with a specific pump fluid and the fluid is an active part of the pumping mechanism. For best performance from your pump, care must be used to select fluid with the physical and chemical properties engineered for your pump. For our pumps the ideal fluid for general purpose pumping is US350. This is a moderately priced fluid that is engineered to give best vacuum and longest life in our pumps. Other fluids may give performance that is good enough for your needs but our specifications are based on regular use of US350.

US350SS Typical Data		
Property	ASTM Test Method	US350SS
Density, lbs. / USG 60 °F	D1298	7.22
Color, ASTM	D1500	<0.5
Flash Point °F	D92	421
Viscosity cSt @ 40°C cSt @ 100°C	D445	46.6 6.97
Viscosity SUV @ 100°C SUV @ 210°C	D445/D2161	240 50
Viscosity Index	D2270	106
Pour Point, °F	D97	0
Emulsion Characteristics Distilled Water @ 130°F ML of water separated (minutes)	D1401	40 (5)
Aniline Point, °F	D611	228
UV Absorptivity (250 mm)	D2008.A4	<0.1

Checking the pump fluid level:

NOTE: When the pump is not running, the pump fluid level appears lower.

NOTE: It is not unusual for the pump fluid to foam because of the churning action within the pump. Foaming is more pronounced at higher operating pressures. If only foam is visible in the sight glass, it means that the pump fluid level is low.

Changing the pump fluid



WARNING: DO NOT USE THE PUMP FOR PUMPING CORROSIVE, TOXIC, OR VOLATILE CHEMICALS OR VAPORS



CAUTION: Hydrocarbon pump fluid should be changed at the following times:

1. After a 100 hour break-in period of pump operation.
2. When the pump fluid becomes contaminated.
3. When condensation in the pump fluid is present.
4. Before and after the pump has been stored for a long period of time.
5. Perfluoropolyether fluid should be reconditioned when it becomes contaminated.

NOTE: Always change the pump fluid while the pump is warm to prevent condensables, such as water, from remaining in the pump.

Turn the pump off and change the fluid as follows:

1. Drain the fluid from the pump. Use your fingers to remove the oil fill cap and the oil drain plug from the pump; allow the fluid to drain into a suitable container. If the fluid fill cap or fluid drain cap cannot be loosened with your fingers, cover them with a cloth and use pliers.
2. After the oil flow diminishes, switch ON the pump, allow it to run for about 10 seconds and then switch it OFF.
3. If the fluid drained from the pump is discolored, contains particulate, has a foul odor or is very dirty, flush out the pump using the procedure below until the drained fluid is clean. If your pump requires more than 2 flushes, a foreline trap or oil filtration unit should be installed on the pump. Contact our company for more information on foreline traps and oil filtration units.
 - a. Reinstall the fluid-drain plug with flat gasket into the fluid-drain port.
 - b. Refill the pump with US350 vacuum pump fluid until the fluid level is visible in the lower rim of the fluid sight glass.
 - c. Reinstall the fluid-fill plug with gasket in the **fluid fill** port.
 - d. Turn **ON** the pump and allow it to run for about 10 minutes.
 - e. Turn the pump **OFF** and refer to step 1 to drain the vacuum fluid.

4. Charge the pump with fluid as follows:
 - a. Reinstall the fluid-drain plug with flat gasket into the fluid-drain port.
 - b. Remove the fluid-fill cap and fill the pump to capacity with VPO-3000 vacuum pump fluid. Using other than VPO-3000 vacuum pump fluid may result in damage to the pump or compromise the pump performance and lifetime.
 - c. Reinstall the fluid-fill cap with flat gasket.

Long Term Storage (2 weeks or longer)

Before placing a pump in long term storage, follow the procedure below:

1. Drain all fluids from the pump as described in the previous section.
2. Refill the pump with clean US350SS vacuum fluid as described in section for changing the pump fluid.
3. Always cover both the intake and exhaust ports with caps to keep any dust or foreign materials from entering the pump. Place pump in original container if available.
4. Be sure that the pump is stored in a horizontal position with the intake and exhaust ports facing up.
5. When putting a pump into storage, put a pin hole in both the intake and exhaust port caps.

Avoiding Oil Leaks During Shipping and Storage

Always drain your vacuum pump of all fluids before shipping. Failure to do so can result in damaged shipping containers and delays by freight carriers due to possibility of the presence of hazardous materials in the event of a spill.

TROUBLE SHOOTING

Symptom	Check	Steps to Take
Noisy motor, will not turn.	<p>Power line voltage and connections</p> <p>Any foreign materials inside the pump.</p> <p>Motor (open internal circuit).</p>	<p>Correct voltage or connections.</p> <p>Remove the foreign materials. If problem is with oil, change oil.</p> <p>Replace open windings.</p>
Noisy and hot pump.	<p>Any foreign materials inside the exhaust valve.</p> <p>Leakage in the system.</p> <p>If leakage, valve is open.</p> <p>All the valves in the vacuum line.</p>	<p>Remove foreign materials.</p> <p>Fix the leakage.</p> <p>Close the valve.</p> <p>Close if found open.</p>
Vacuum drops (gets worse).	<p>Oil level.</p> <p>Leakage on the device connected.</p> <p>Moisture content of oil.</p> <p>Oil regulator.</p> <p>If gas ballast is open.</p>	<p>Add oil.</p> <p>Close the intake and recheck.</p> <p>Change oil.</p> <p>Replace.</p> <p>Close the gas ballast.</p>
Motor runs, but not pump.	<p>Worn out coupling mechanism.</p> <p>Worn out key between motor and pump.</p>	<p>Replace coupling.</p> <p>Replace the key and the set screws.</p>

EXPLODED VIEW
“USV” SERIES VACUUM PUMPS

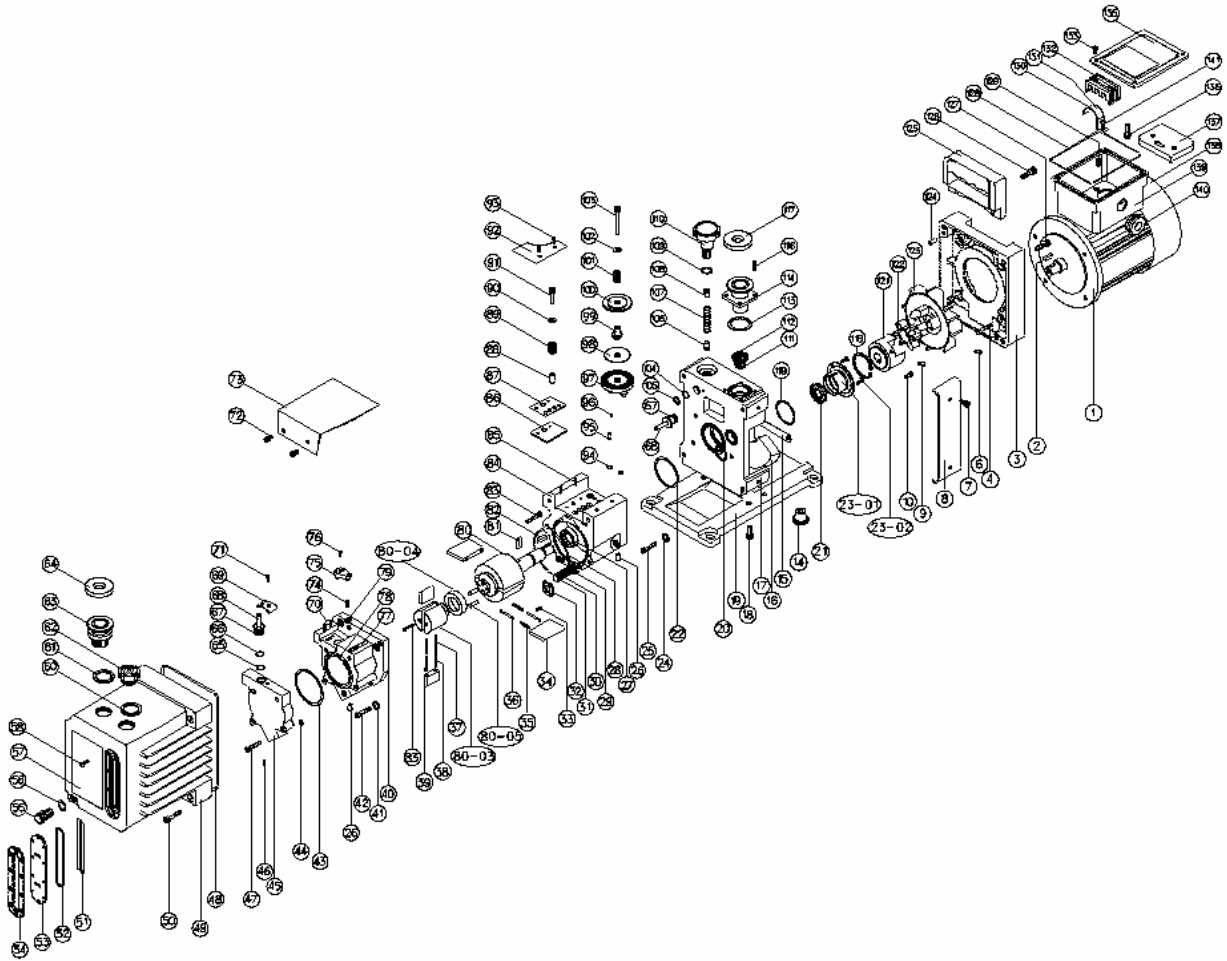

US200-7

EXPLODED VIEW
“USV” SERIES VACUUM PUMPS

(CON'T)

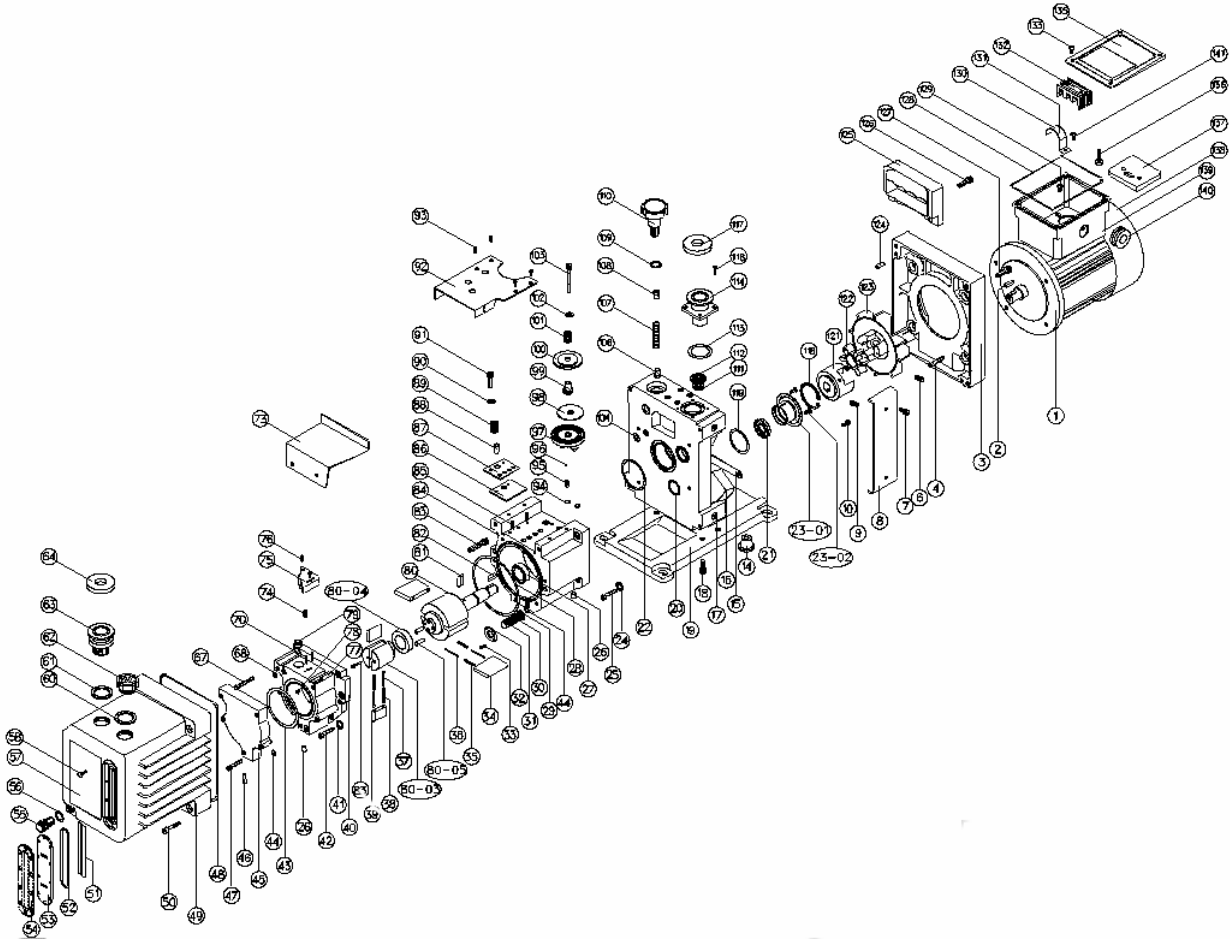

US400-14

WARRANTY– VACUUM PRODUCTS

Subject to terms and conditions hereinafter set forth and set forth in General Terms of Sale, US Vacuum Pumps LLC (the seller) warrants products of its manufacturer, when shipped, and its work (including installation & start-up) when performed, will be of good quality and will be free from defects in material and workmanship. This warranty applies only to sellers equipment, under use and service in accordance with seller's written instructions, recommendations and ratings for installation, operating, maintenance and service of products for a period of 12 months. Because of varying conditions of installation and operation, all guarantees of performance are subject to plus or minus 5% variation.

THIS WARRANTY EXTENDS ONLY TO BUYER AND/OR ORIGINAL END USER, AND IN NO EVENT SHALL THE SELLER BE LIABLE FOR PROPERTY DAMAGE SUSTAINED BY A PERSON DESIGNATED BY THE LAW OF ANY JURISDICTION AS A THIRD PARTY BENEFICIARY OF THIS WARRANTY OR ANY OTHER WARRANTY HELD TO SURVIVE SELLER'S DISCLAIMER.

All accessories furnished by seller but manufactured by others bear only that manufacturer's standard warranty.

All claims for defective products, parts, or work under this warranty must be made in writing immediately upon discovery and, in any event within one (1) year from date of shipment of the applicable item by seller. Unless done with prior written consent of seller, any repairs, alterations or disassembly of sellers equipment shall void warranty. Installation and transportation costs are not included and defective items must be held for seller's inspection and returned to sellers Ex-works point upon request.

THERE ARE NO WARRANTIES, EXPRESSED, IMPLIED OR STATUTORY WHICH EXTENDS BEYOND THE DESCRIPTION ON THE FACE HEREOF, INCLUDING WITHOUT LIMITATION, THE IMPLIED WARRANTIES OF MERCHANTABILITY AND FITNESS OF PURPOSE.

After buyers submission of a claim as provided above and its approval, seller shall at its option either repair or replace its product, part, or work at the original Ex-works point of shipment, or refund an equitable portion of the purchase price.

The products and parts sold hereunder are not warranted for operation with erosive or corrosive materials or those which may lead to a build-up of material within the product supplied, nor those which are incompatible with the materials of construction. The buyer shall have no claim whatsoever and no product or part shall be deemed to be defective by reason of failure to resist erosive or corrosive action nor for problems resulting from build-up of material within the unit nor for problems due to incompatibility with the materials of construction.

Any improper use, operation beyond capacity, substitution of parts not approved by seller, or any alteration or repairs by others in such manner as in sellers judgment affects the product materially and adversely shall void this warranty.

No employee or representative of seller other than an officer of US Vacuum Pumps LLC is Authorized to change this warranty in any way or grant any other warranty. Any such change by an officer of the company must be in writing.

In no event shall buyer be entitled to incidental or consequential damages. Any action for breach of this agreement must commence within (1) year after the cause of action has occurred.



**US VACUUM PUMPS LLC
P.O. BOX 909
CANTON, TX 75103
PH: 888-416-7366 FX: 877-416-7599**