



US VACUUM PUMPS LLC

USV-15F ROTARY VANE SINGLE STAGE VACUUM PUMP



US VACUUM pump Model USV-15F is a Single stage, Air-cooled, Rotary vane vacuum pump capable of producing an ultimate vacuum to 2 mm Hg (29.8" Hg).

The pump is small and compact yet produces a very generous 15 cfm of inlet pumping capacity. Typical applications include vacuum drying, impregnation, food packaging, vacuum chucking and de-gassing.

Available standard with 120v Starter box with overload, power cord & N. American plug. Other voltages available

TECHNICAL DATA

PUMP TYPE		USV-15F
Pump Displacement	CFM	15
Ultimate Vacuum	Torr	2
Pump Speed	RPM	3500
Oil Capacity	ml	500
Inlet connection	Inch	1/2
Motor-Installed power	HP	1.5
Weight	LBS	42
Noise level	db(A)	72

Vacuum Tank system

- 15 cfm Vacuum pump
- 30 gallon tank
- 2hp Motor
- Inlet Filter
- Starter box
- Vacuum switch with H-O-A operation
- Rubber mounts
- 120V (1-PH)
- Other voltages available



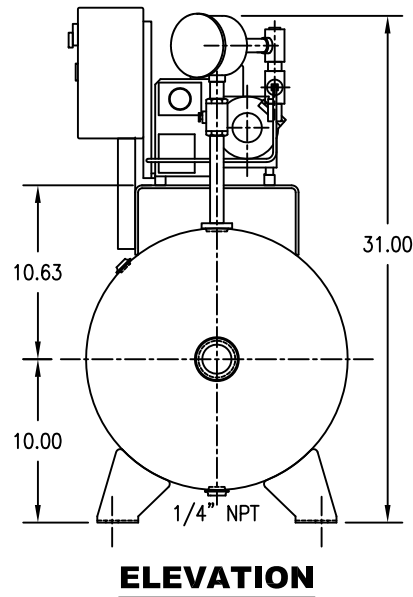
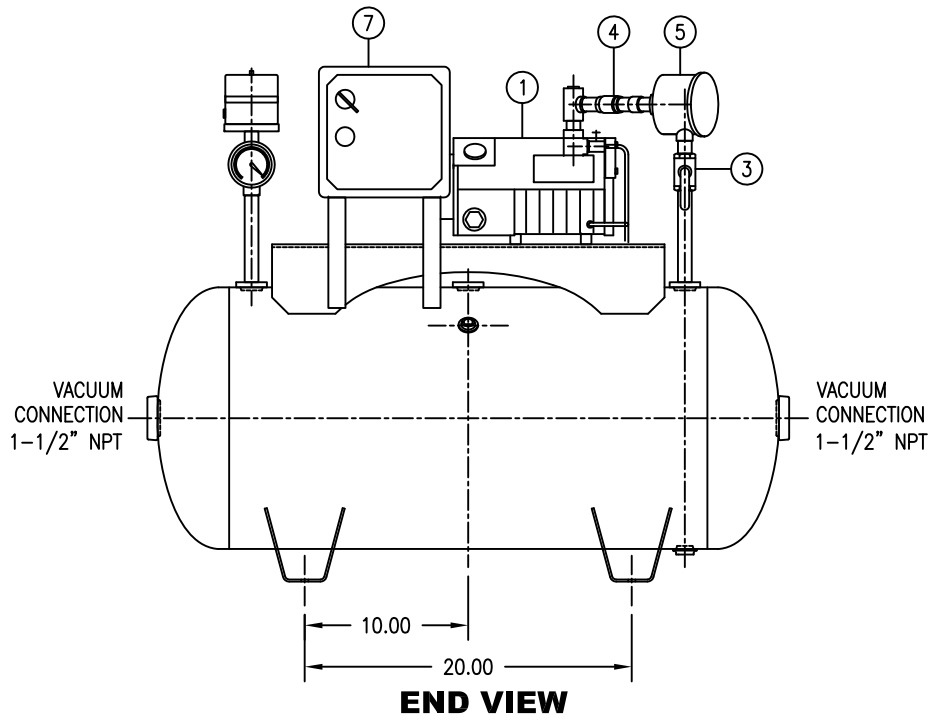
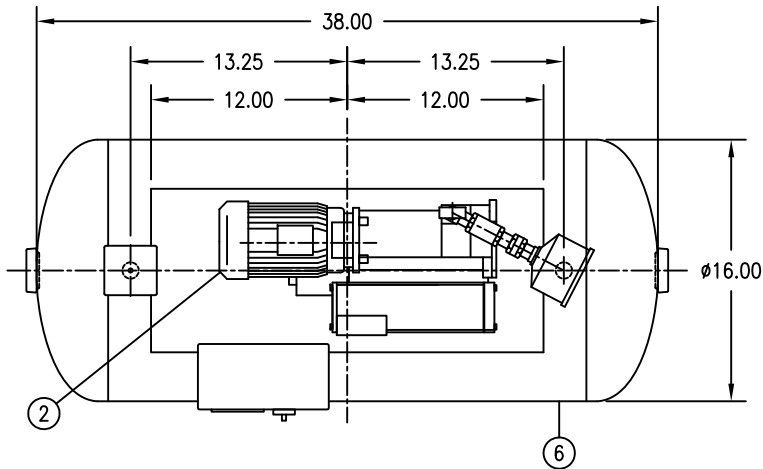

BILL OF MATERIAL			
NO.	QTY	DESCRIPTION	PART NUMBER
1	1	VACUUM PUMP MODEL USV#15F	USV15F
2	1	ELECTRIC MOTOR 2HP, 115#230V, 60HZ	EMCPS15B1.25
3	1	ISOLATION VALVE, BRASS 1/2"	IBVCPS15B.50
4	1	CHECK VALVE, ALUMINUM 1/2"	CVCPS15B.50
5	1	PARTICULATE FILTER	VFISL824050
6	1	TANK, 30 GALLON	US302470
7	1	STARTER BOX, 120V	MSCPS15B110

- NOTES:
1. ALL STANDARD UNIT PIPING SHALL BE SCH/40 ASTM A-53 TYPE F C/W 150# ASTM A-197 MALLEABLE IRON THREADED FITTINGS.
 2. DIMENSION TOLERANCE TO 1/4".
 3. CUSTOMER IS RESPONSIBLE FOR PROPER LIFTING EQUIPMENT FOR LIFTING SKID.
 4. ANCHOR BOLTS ARE NOT FURNISHED WITH UNIT.

0	INITIAL RELEASE				JCM	PD	PD	07-APR-20
REV	DESCRIPTION				DWN	CK	APP	DATE
DWN	JCM	07-APR-20	<small>THIS DRAWING AND ALL INFORMATION SHOWN HEREON ARE THE EXCLUSIVE PROPERTY OF US VACUUM PUMPS, LLC. AND ARE SUBMITTED ON A CONFIDENTIAL BASIS ONLY. THE RECIPIENT AGREES NOT TO REPRODUCE THE DISCLOSURE OF THE DRAWING OR THE INFORMATION DRAWING, TO RETURN IT UPON REQUEST, AND THAT NO SHOW HEREON WILL BE MADE TO THE THIRD PARTY WITHOUT PRIOR WRITTEN CONSENT OF US VACUUM PUMPS, LLC.</small>			CERTIFIED DRAWING US VACUUM PUMPS, LLC		
CK	PD	07-APR-20						
APP	PD	07-APR-20						
SCALE	NTS				P.O. BOX 909 CANTON, TEXAS 75103 PH: 888-416-7466 / FAX: 877-416-7599			
USV-15F-30 VACUUM PUMP SYSTEM w/ HORIZONTAL RECEIVER								
					USV-15F.30H.115	0		

DIMENSIONS ARE IN INCHES [mm]
 WEIGHT IN LBS [kg]

THIRD ANGLE
 PROJECTION