



Inlet Air Ejectors

An inlet air ejector is a simple device which may be added to the inlet of a 2-stage liquid ring vacuum pump to provide an additional pumping stage. With no increase in horsepower, the air ejector can achieve significantly lower pressures than are possible with the vacuum pump alone.

The operation of the air ejector is similar to that of a water educator except that ambient air or recirculated discharge gas is used to provide the motive force for compressing the process gas from system pressure to the liquid ring pump's inlet pressure. The liquid ring pump handles both the process gas and motive gas.

With an air ejector, inlet pressures as low as 5 torr can be achieved. Pumping capacity at 15 torr and above is equal to about 50% of the capacity of the liquid ring pump alone when operating at 100 torr under standard conditions.

FEATURES

- Max Vac to 5 Torr
- No moving parts
- Simple design for reliability
- Bypass line for full pumping capacity

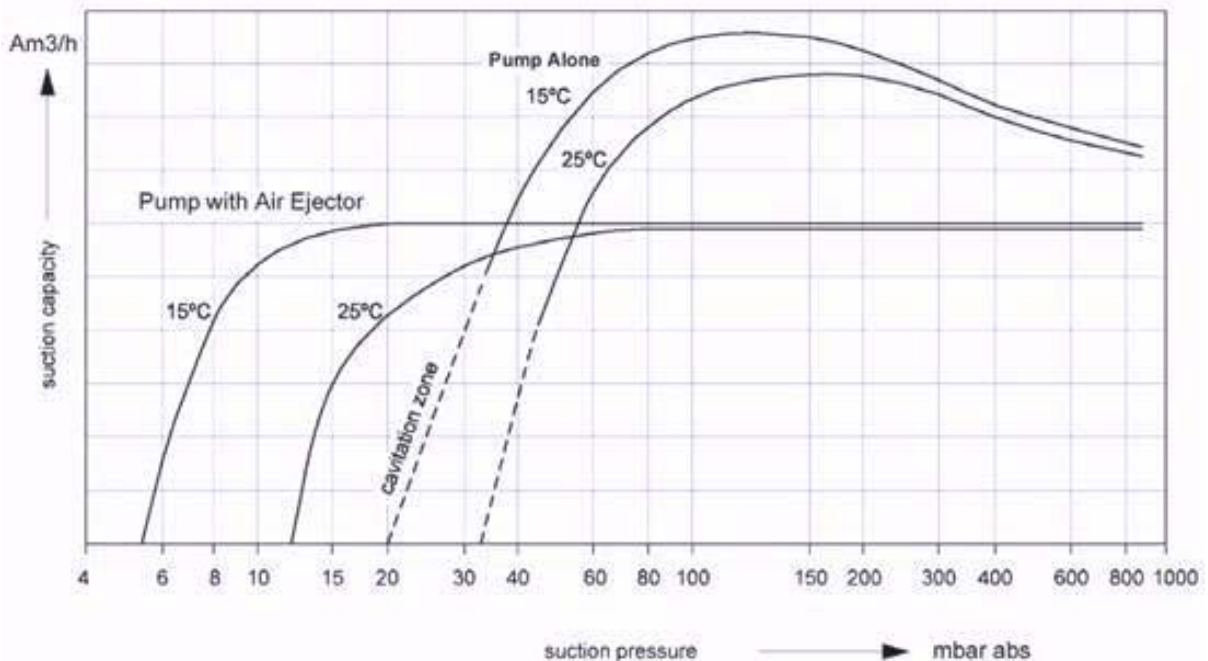
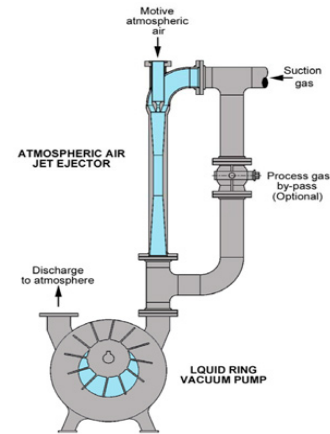
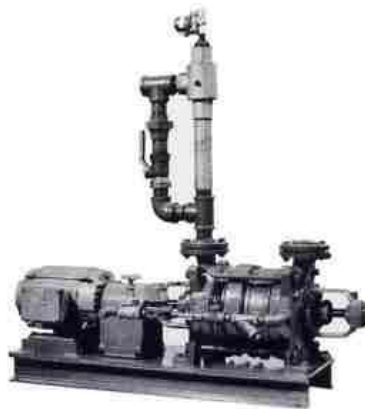

Pumping Speed Vs Pressure

(seal water up to 80 deg F)

Liquid Ring Model	Hp	Ejector ACFM at suction pressures (Torr)				
		5	10	15	20	25
LRH-45	5	7	11	11	12	12
LRH-75	7.5	14	27	30	30	30
LRH-140	10	35	65	73	75	75
LRH-200	15	48	85	85	100	100
LRH-250	20	66	118	118	126	130
LRH-300	25	80	135	156	162	170
LRH-400	40	116	170	179	185	200
LRH-500	50	125	214	225	234	252
LRH-850	75	251	367	386	400	432

US VACUUM

US Vacuum Pumps LLC
P.O. Box 909
Canton, TX 75103
Phone: (888) 416-7366
Fax: (877) 416-7599
WEB: www.usvacuumpumps.com



Atmospheric Air Ejector Dimensions

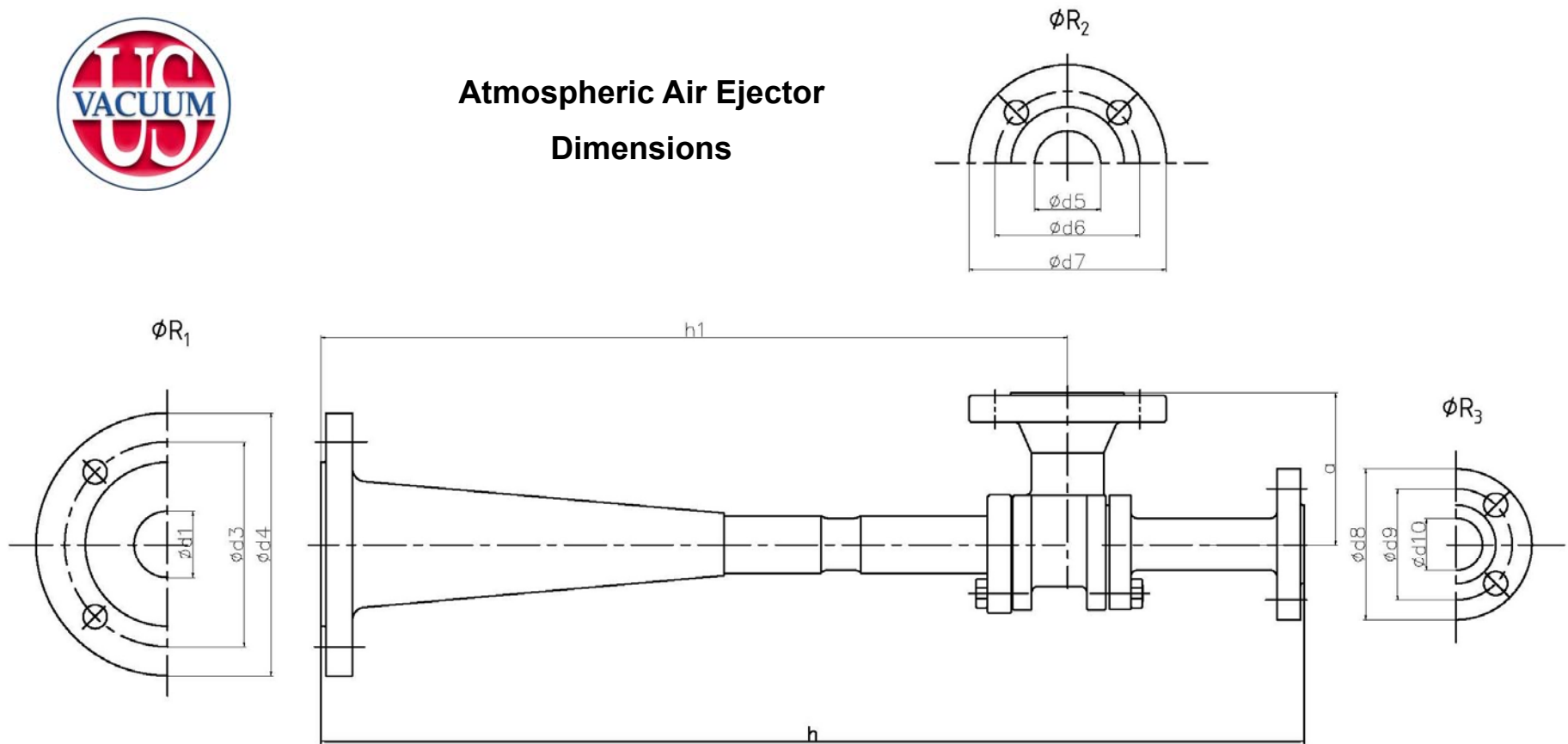

Model	Pump CFM	a	d1	d3	d4	d5	d6	d7	d8	d9	d10	h	h1	R1	R2	R3
5	300	114	51	121	165	40	98.5	130	115	80	25	590	412	2	1.5	1
4	200	114	51	121	165	40	98.5	130	115	80	25	590	412	2	1.5	1
3	125	104	41	98.5	140	32	89	120	115	80	25	530	352	1.5	1.25	1
2	100	100	41	98.5	140	25	80	115	105	70	20	263	189	1.5	1	3/4
1	75	100	41	98.5	140	25	80	115	105	70	20	263	189	1.5	1	3/4

ANSI FLANGE (in)