



# US VACUUM PUMPS LLC

## LRH-15/35/45 DIMENSIONS

BARE SHAFT CONSTRUCTION W/ MECHANICAL SEAL



US VACUUM LRH pumps are Two stage liquid ring vacuum pumps capable of producing a vacuum to 29" Hg . The pumps are available in various materials of construction ( FS = Iron/Stainless steel, SS = All stainless steel ).

Pumps are provided with threaded connections for service liquid, pump draining, vacuum relief valve and companion flanges. Optional items include inlet check valve, vacuum relief valve, flow control, solenoid valve, vacuum and temperature gauges.

Pumps can also come as completely packaged units using water or water as a seal fluid.

### TECHNICAL DATA

PUMP TYPE		LRH 15	LRH 35	LRH 45
Pumping Capacity (@ 25" Hg)	CFM	15	33	44
Speed	RPM	3500	3500	3500
Motor-Installed power	HP	2	3	5
Average service liquid flow	GPM	1.5	1.5	3.5
Noise level at 60 Torr	db(A)	69	69	69
Minimum suction pressure	Torr	25	25	25

DATA BASED ON :  
 DRY AIR AT 68 °F - 20 °C  
 SATURATED AIR AT 68 °F - 20 °C  
 SERVICE LIQUID WATER  
 SERVICE LIQUID TEMPERATURE 59 °F - 15 °C  
 DISCHARGE PRESSURE 1013 mbar

S.S. PUMPS  
 CAPACITY : -10%

Tol.: 10%

PERFORMANCE DATA  
 LIQUID RING VACUUM PUMP  
 PUMP MODEL

**LRH-15**

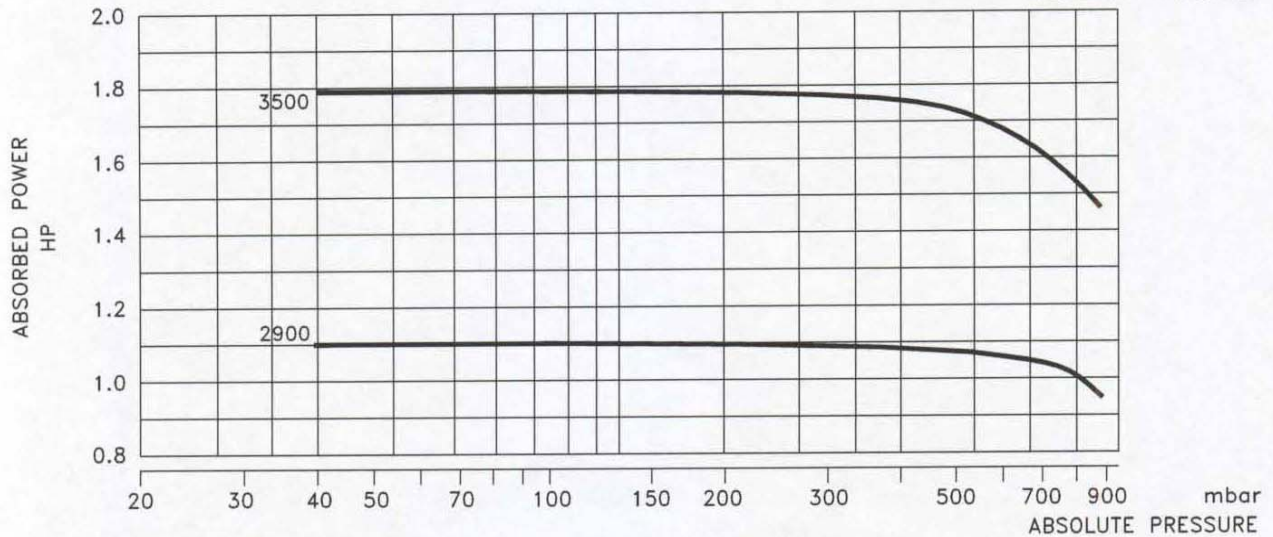
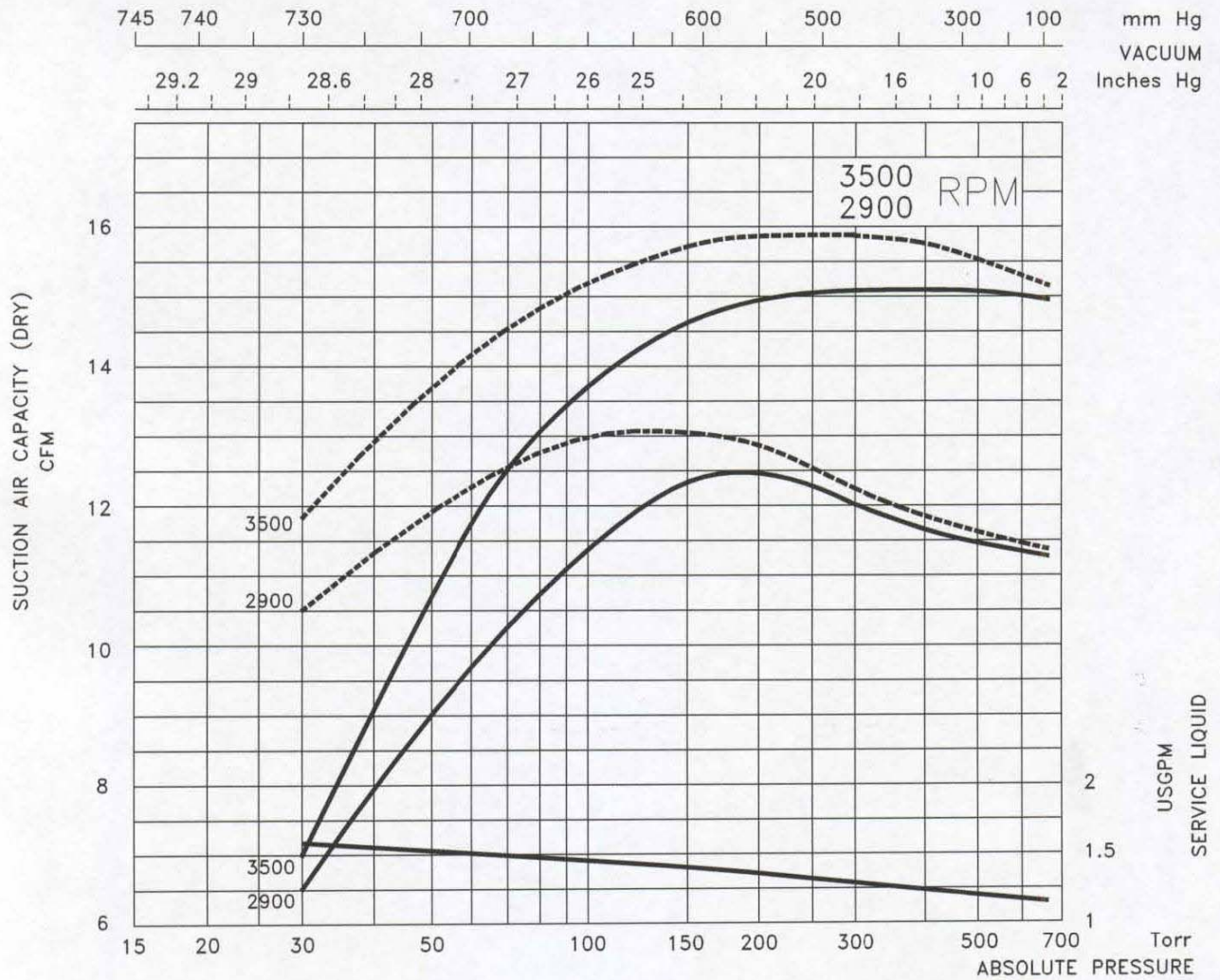

DATA BASED ON :  
 DRY AIR AT 68 °F - 20 °C  
 SATURATED AIR AT 68 °F - 20 °C  
 SERVICE LIQUID WATER  
 SERVICE LIQUID TEMPERATURE 59 °F - 15 °C  
 DISCHARGE PRESSURE 1013 mbar

S.S. PUMPS  
 CAPACITY : -10%

PERFORMANCE DATA  
 LIQUID RING VACUUM PUMP  
 PUMP MODEL  
**LRH-35**

Tol.: 10%

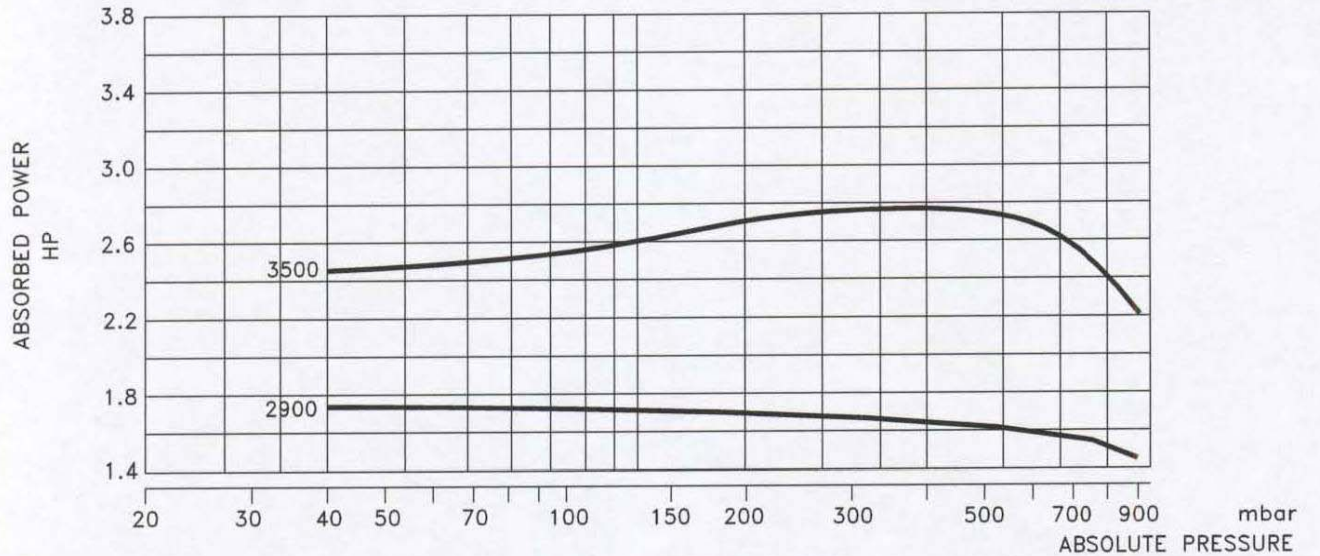
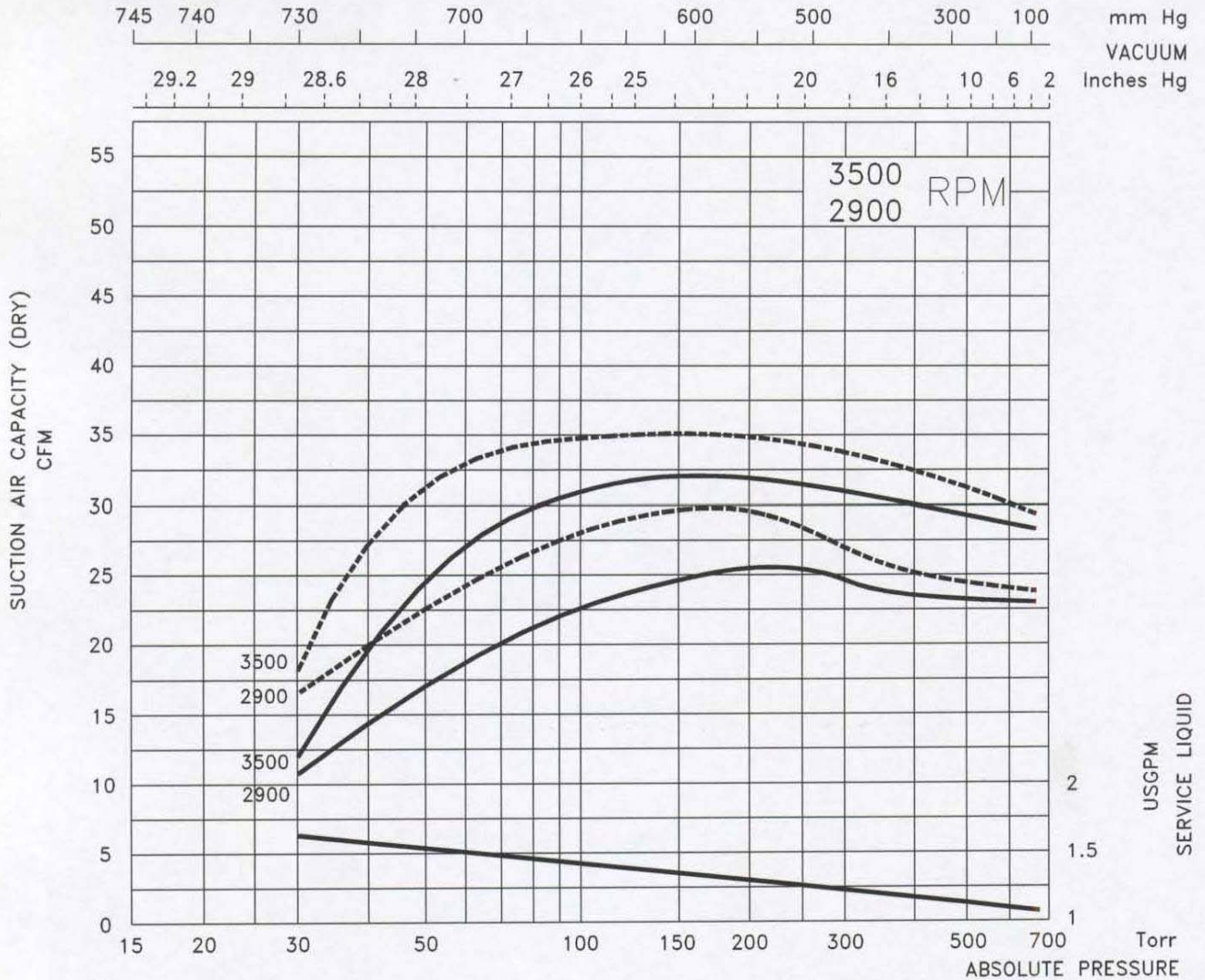

DATA BASED ON :  
 DRY AIR AT 68 °F - 20 °C  
 SATURATED AIR AT 68 °F - 20 °C  
 SERVICE LIQUID WATER  
 SERVICE LIQUID TEMPERATURE 59 °F - 15 °C  
 DISCHARGE PRESSURE 1013 mbar

S.S. PUMPS  
 CAPACITY : -10%

Tol.: 10%

PERFORMANCE DATA  
 LIQUID RING VACUUM PUMP  
 PUMP MODEL

LRH-45



# DIMENSIONS

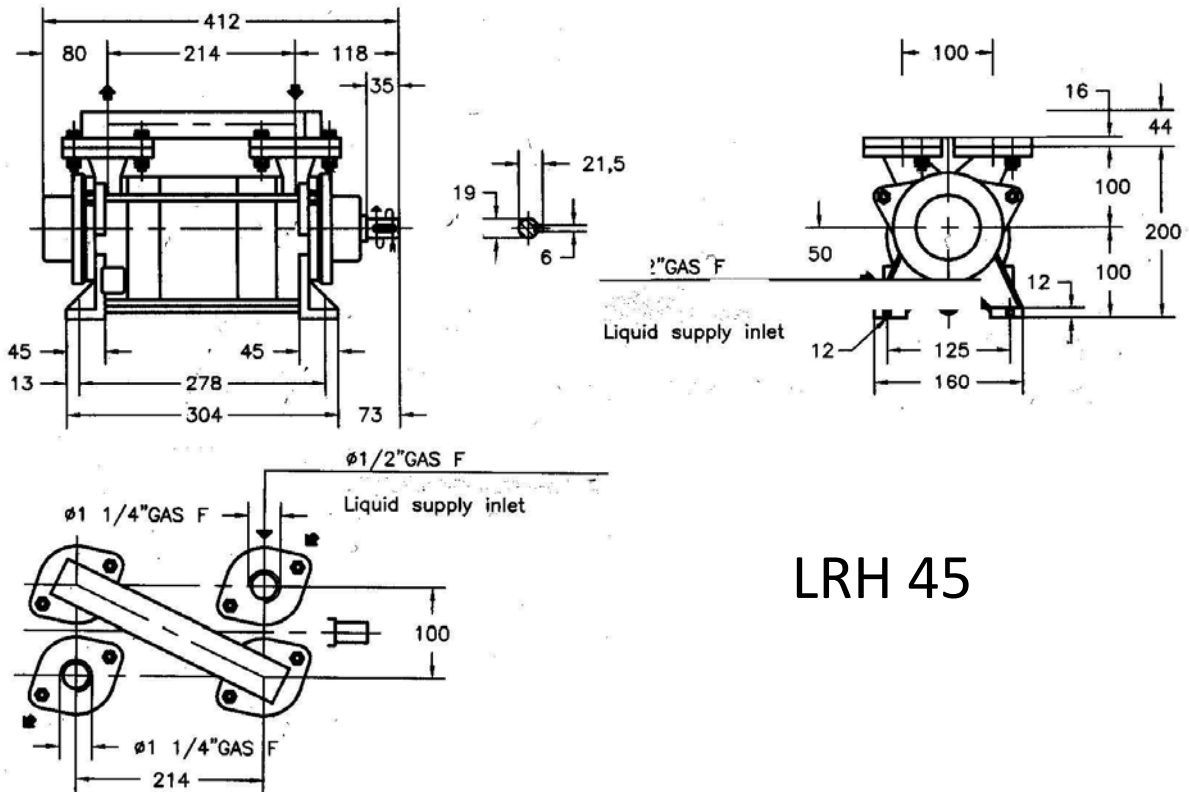
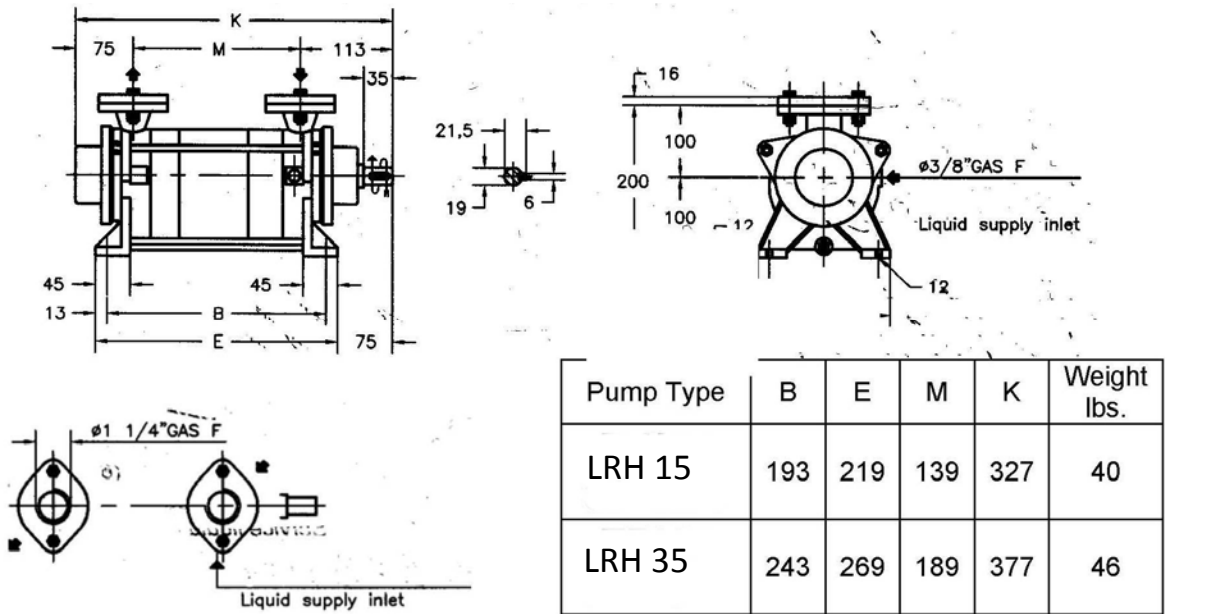

LRH 45