



# US VACUUM PUMPS LLC

## LVT-200 & LVT-300

BARE SHAFT CONSTRUCTION W/ MECHANICAL SEAL



U.S. VACUUM LVT pumps are single stage liquid ring vacuum pumps capable of producing a vacuum to 29" Hg . The pumps are available in various materials of construction ( FB = Iron/Bronze, FS = Iron/Stainless steel, SS = All stainless steel ).

Pumps are provided with threaded connections for service liquid, pump draining, vacuum relief valve and companion flanges. Optional items include inlet check valve, vacuum relief valve, flow control, solenoid valve, vacuum and temperature gauges.

Pumps can also come as completely packaged units using water or water as a seal fluid.

### TECHNICAL DATA

PUMP TYPE		LVT 200	LVT 300
Pumping Capacity (@26" Hg)	CFM	180	275
Speed	RPM	1750	1750
Motor-Installed power	HP	15	20
Average service liquid flow	GPM	7	9
Noise level at 100 Torr	db(A)	73	73
Minimum suction pressure	Torr	25	25

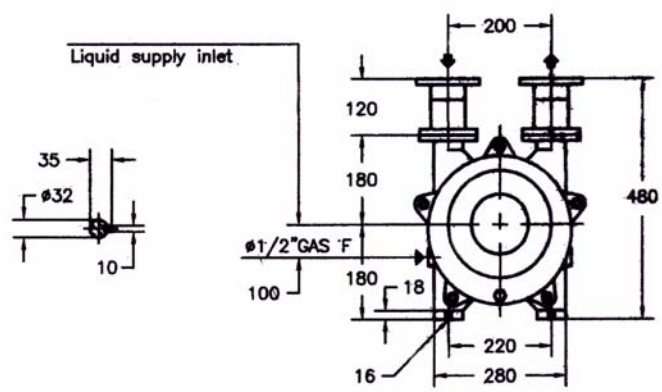
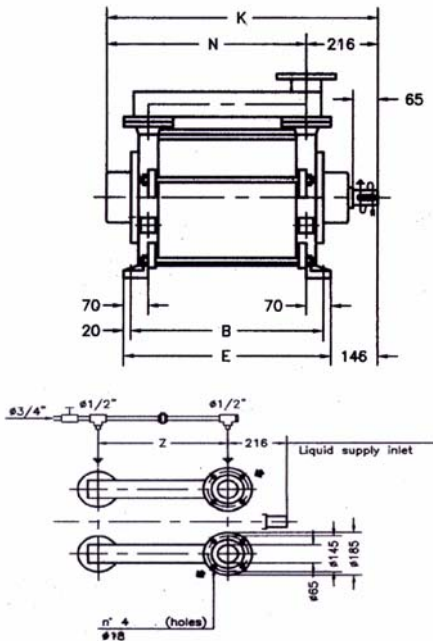

Pump Type	B	E	K	N	Weight lbs
LVT 200	354	394	614	398	298
LVT 300	424	464	684	468	321

NOTE: Dimensions in mm  
(1" = 25.4 mm)

DATA BASED ON :  
 DRY AIR AT 68 °F - 20 °C  
 SATURATED AIR AT 68 °F - 20 °C  
 SERVICE LIQUID WATER  
 SERVICE LIQUID TEMPERATURE 59 °F - 15 °C  
 DISCHARGE PRESSURE 1013 mbar

S.S. PUMPS  
 CAPACITY : -10%

PERFORMANCE DATA  
 LIQUID RING VACUUM PUMP  
 PUMP MODEL  
**LVT 200**

Tol.: 10%

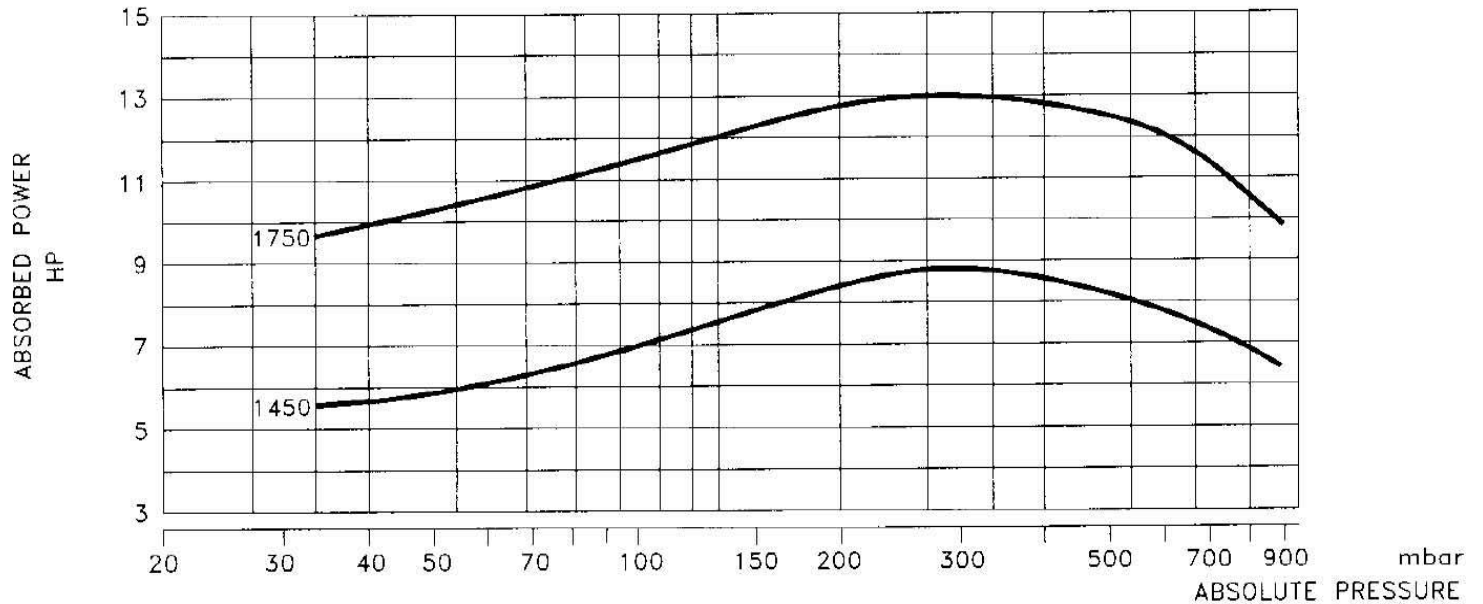
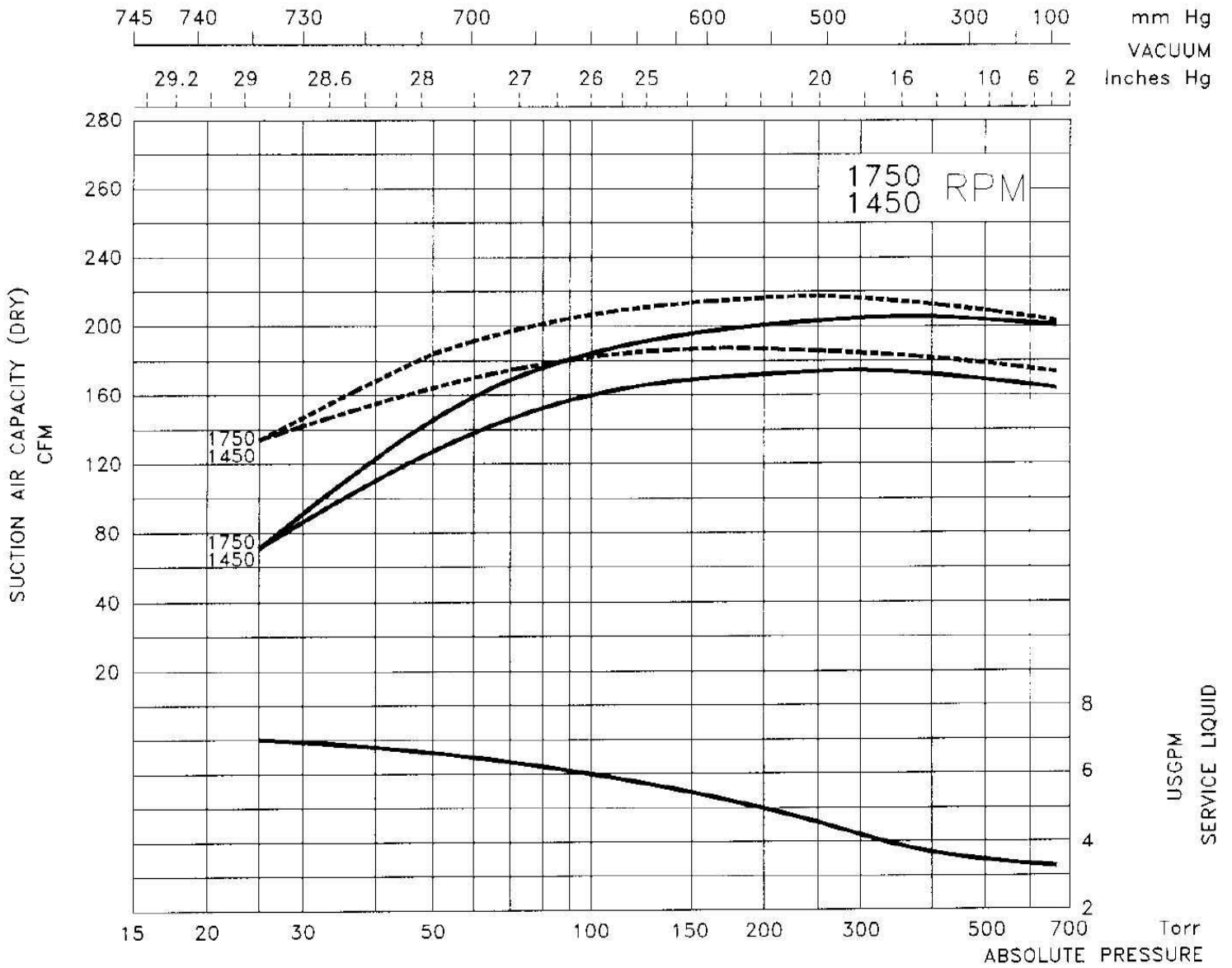

DATA BASED ON :

DRY AIR AT 68 °F - 20 °C  
 SATURATED AIR AT 68 °F - 20 °C  
 SERVICE LIQUID WATER  
 SERVICE LIQUID TEMPERATURE 59 °F - 15 °C  
 DISCHARGE PRESSURE 1013 mbar

S.S. PUMPS  
 CAPACITY : -10%

Tol.: 10%

PERFORMANCE DATA  
 LIQUID RING VACUUM PUMP  
 PUMP MODEL

**LVT 300**

