



U.S. VACUUM PUMPS LLC

LVT-400CT/LVT-500CT

BARE SHAFT CONSTRUCTION W/ MECHANICAL SEAL



U.S. VACUUM LVT pumps are single stage liquid ring vacuum pumps capable of producing a vacuum to 26" Hg . The pumps are available in various materials of construction (FS = Iron/Stainless steel, SS = All stainless steel).

Pumps are provided with threaded connections for service liquid, pump draining, vacuum relief valve and companion flanges. Optional items include inlet check valve, vacuum relief valve, flow control, solenoid valve, vacuum and temperature gauges.

Pumps can also come as completely packaged units using water or water as a seal fluid.

TECHNICAL DATA

PUMP TYPE		LVT-400CT	LVT-500CT
Pumping Capacity (@18" Hg)	CFM	377	500
Speed	RPM	1750	1750
Motor-Installed power	HP	25	40
Average service liquid flow	GPM	10	10
Noise level at 150 Torr	db(A)	78	78
Minimum suction pressure	Torr	90	90

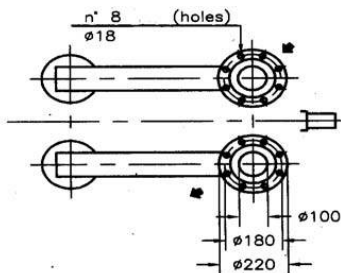
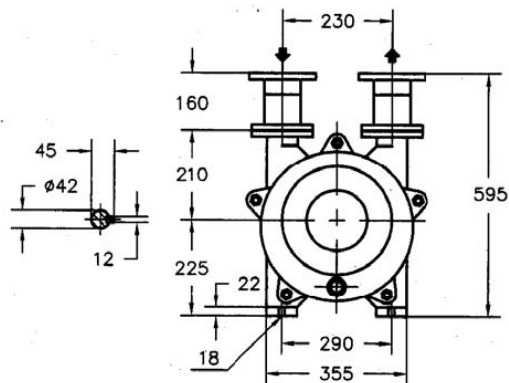
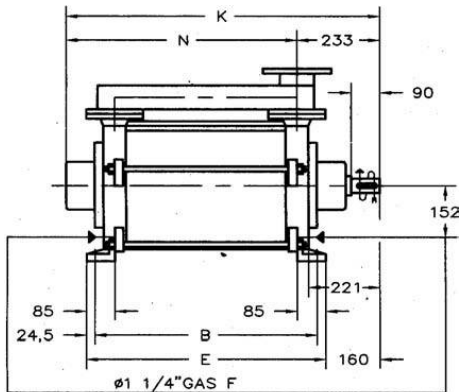

Pump Type	B	E	K	N	Weight lbs
LVT-400CT	447	496	722	489	440
LVT-500CT	512	561	787	554	506

NOTE: Dimensions in mm
(1" = 25.4 mm)

DATA BASED ON :
 DRY AIR AT 68 °F - 20 °C
 SATURATED AIR AT 68 °F - 20 °C
 SERVICE LIQUID WATER
 SERVICE LIQUID TEMPERATURE 59 °F - 15 °C
 DISCHARGE PRESSURE 1013 mbar

S.S. PUMPS
 CAPACITY : -10%

Tol.: 10%

PERFORMANCE DATA
 LIQUID RING VACUUM PUMP
 PUMP MODEL
LVT-400CT

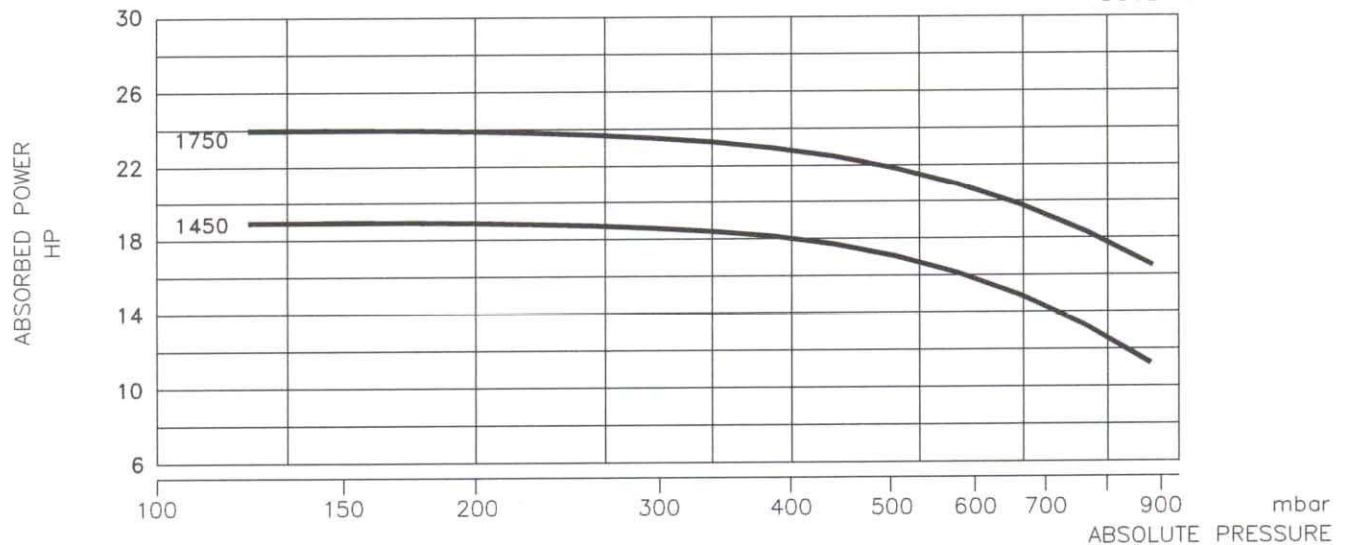
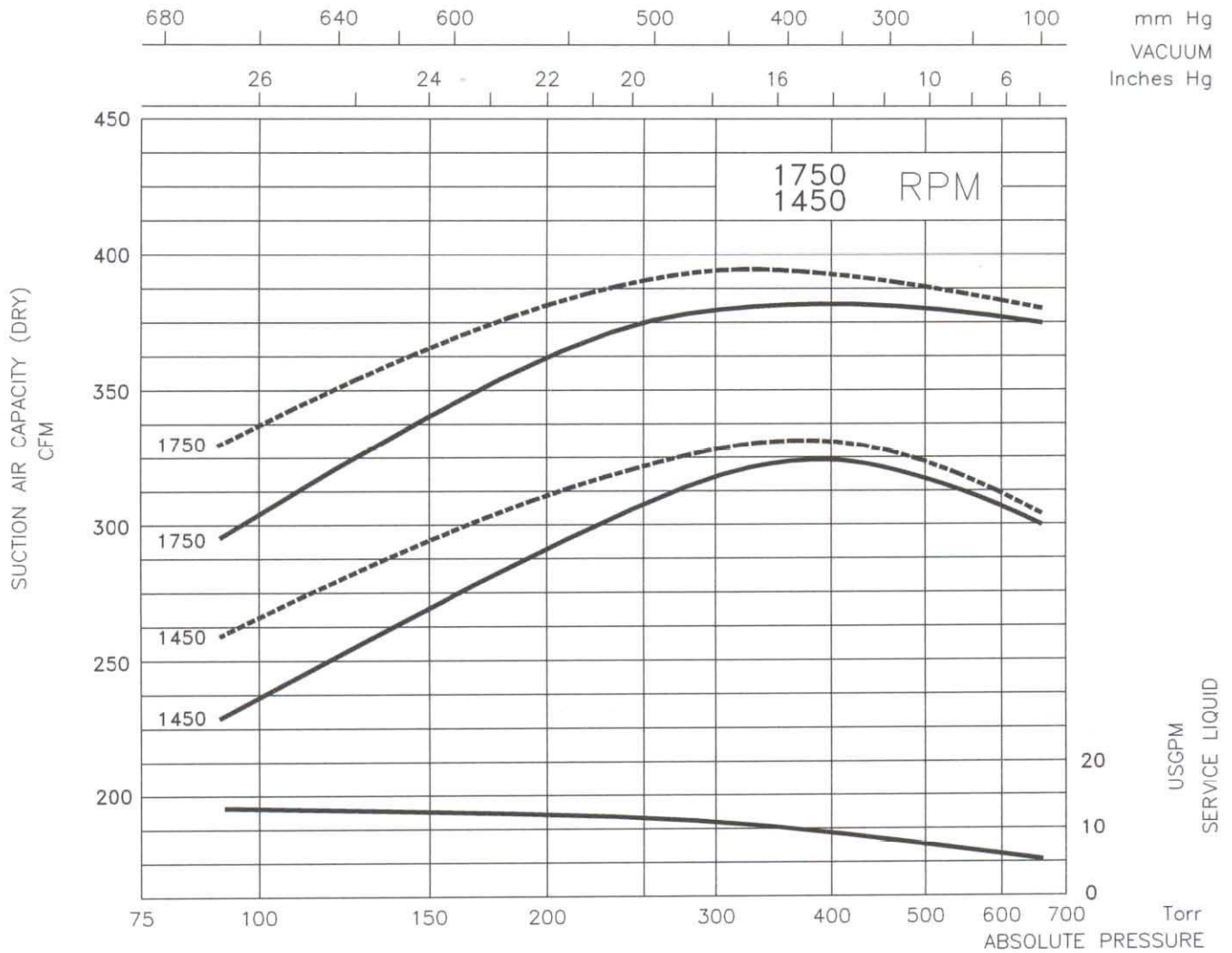

DATA BASED ON :
 DRY AIR AT 68 °F - 20 °C
 SATURATED AIR AT 68 °F - 20 °C
 SERVICE LIQUID WATER
 SERVICE LIQUID TEMPERATURE 59 °F - 15 °C
 DISCHARGE PRESSURE 1013 mbar

S.S. PUMPS
 CAPACITY : -10%

PERFORMANCE DATA
 LIQUID RING VACUUM PUMP
 PUMP MODEL

LVT-500CT

Tol.: 10%

